



## CONTENT

> Congratulations	p. 2
> Bicycle Safety	p. 2
> Saddle height	p. 3
> Suspension on Scott mountain bikes	p. 3
> Gears	p. 4
> Adjustment of the Index rear derailleur	p. 4
> Adjustment of the front derailleur	p. 5
> Chain maintenance	p. 7
> Operation Rapid Fire Plus system	p. 7
> Brakes	p. 12
> Tires and rims	p. 15
> Maintenance and care	p. 21
> Bicycle care	p. 23
> Trouble shooting	p. 25
> Warranty	p. 26
> Parts of wear and tear	p. 27
> Protocol for handing over	p. 29

## CONGRATULATIONS!

Congratulations on your purchase of a new Scott bicycle! We are confident that the bicycle will exceed your expectations for value, performance, and ride quality. Each frame set and component has been custom specified and designed to enhance your riding experience. Whether you are a beginning cyclist, or a seasoned pro, Scott bicycles will provide endless hours of two-wheeled fun.

We strongly encourage you to take the time to read this manual and familiarise yourself with your new bicycle. If you have purchased a bike for your children, please take the time to make sure they understand the information contained in this Owner's Manual.

### Important!

**If you purchased this bicycle for a minor, it is essential that a responsible adult/parent thoroughly reviews and reads the Owner's Manual to the minor.**

Please make sure to get your Scott bike completely assembled from your authorized Scott dealer.

This is very important for optimum performance and safety and guarantees you a long lasting joy while riding your bike.

It is important to understand the basics of riding a bicycle, but it is equally important to exercise common sense when cycling. Cycling is a dynamic sport and requires reacting to varying situations. Like any sports, cycling involves risk of injury and damage. By choosing to ride a bicycle, you assume the responsibility for that risk.

### Important!

**Please use the bike of your choice only for the purpose it was made for.**

**For instance a road racing bike can not be used to substitute a mountain bike in off road terrain or a Trekking bike can not be used for downhill racing or road racing.**

If you have questions or problems regarding your new Scott bicycle, please contact your Authorised Dealer.

## BICYCLE SAFETY

1. Obey all traffic laws,
2. Make sure that the bike size is right for the rider, and that he can reach brake levers properly.
3. Make sure that the brakes and the bicycle work perfectly well (cf maintenance).
4. Always have a light at night and install reflectors properly,
5. Never ride two people on a bicycle designed for one (except specially designed and properly installed child carriers.).
6. Never hitch a ride on another vehicle.
7. Do not weave or race in traffic.
8. Watch out for parked cars (door can be opened at any time) and cars pulling into traffic.
9. Use proper signals when turning.
10. Mount loads securely. Never carry packages that interfere with brakes or vision.
11. Always wear a helmet.

## SADDLE HEIGHT

### Saddle height

Comfortable riding not only depends on the position of the saddle, but also on its height. You can accurately adjust the height of the saddle to the length of your legs when you proceed as follows:

1. Straddle the saddle. Place the ball of your foot on the pedal nearest to the ground. Make sure the cranks are vertical.
2. If the heel of your foot points down about 30 degrees, the height of the saddle is correct.

### CAUTION!

Make sure that the limit mark on your seat post is inside the seat tube. If it is not possible to reach the correct seat height, you have to choose a size above.

Make sure that this mark is inserted into the frame.

If you need to change the inclination of the saddle or the horizontal position, please make sure not to exceed the max. tightening torque.

Screws with M5 should be tightened with 6 Nm, M8 with 20 Nm.

Please make sure the saddle is connected perfect with the seat post before every ride.

Please note that Scott is not responsible for damages caused by neglecting the tightening torques on the seat-clamp fixing screws.

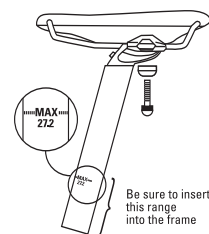

Ride Frequently!

## CHANGING GEARS

### Introduction on derailleur

The front and the rear derailleur have already been adjusted by your Scott dealer. Therefore, no readjustment will be necessary to begin with. However, it is advisable to check the adjustment of the gear change mechanism regularly.

When the gear lever is fully pushed towards the front, the chain should be below the smallest or the biggest sprocket.

When the adjustment of the derailleur is inaccurate, for example when the chain is a little slack, it can jump off either between the biggest sprocket and the spoke on the left side and/or between the smallest sprocket and the frame on the right side. This can lead to severe damages and/or a fall.

The adjustment of the rear derailleur must not be too slack (causing the chain to derail), nor too tight. In the latter case, chain noise occurs when the chain is on the smallest or largest sprocket. The stroke of the derailleur can be limited both on the left and the right side by means of two limit screws.

## ADJUSTMENT OF THE INDEX REAR DERAILLEUR

All Scott bikes are fitted with a so-called index rear derailleur. This derailleur can be positioned exactly below the required sprocket through pre-programmed "clicking". Changing gears is easy with the index system, provided it is properly adjusted. Contrary to the adjustment of any ordinary derailleur, the adjustment of the index derailleur requires special attention and is therefore best left to your Scott dealer. Should you nevertheless want to adjust the index system yourself, proceed as follows:

1. Change to the largest gear (smallest rear sprocket).

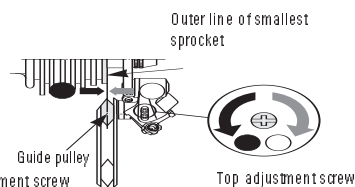

### Top adjustment

Turn the top adjustment screw to adjust so that the guide pulley is in line with the outer line of the smallest sprocket when looking from the rear.

2. Drive the pedals forward a few times. In case of chain noise, adjust the derailleur with the adjusting screws.
3. Pull the derailleur control cable tight and secure it with the cable screw in the rear derailleur to tighten the cable screw even further.
4. Use the shift lever to change to the next sprocket. There should be no chain noise. If necessary, adjust the cable screw.

## ADJUSTMENT OF THE INDEX REAR DERAILLEUR

### Low adjustment

Turn the low adjustment screw so that the guide pulley moves to a position directly in line with the largest sprocket.

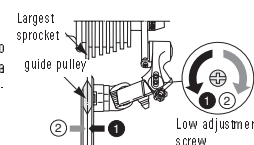

### How to use the B-tension adjustment screw

Mount the chain on the smallest chaining and the largest sprocket, and turn the crank arm backward. Then turn the B-tension adjustment screw to adjust the guide pulley as close to the sprocket as possible but not so close that it touches. Next, set the chain to the smallest sprocket and repeat the above to make sure that the pulley does not touch the sprocket.

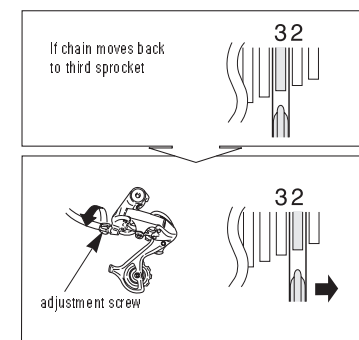
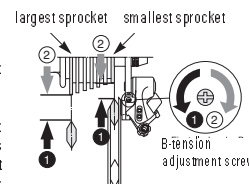

Tighten the adjustment screw until the chain moves back to the second sprocket (counterclockwise).

## ADJUSTMENT OF THE FRONT DERAILLEUR

Usually, the front derailleur is secured to the seat tube with a clamping strip, fitted with a bolt. As a result the derailleur can be moved up/down and turned, the front derailleur can be adjusted in such a way that the chain does not derail when the derailleur is in its highest position. The derailleur should not protrude beyond the largest chain wheel by more than 2 mm and must not touch the pedal crank. For correct adjustment proceed as follows.

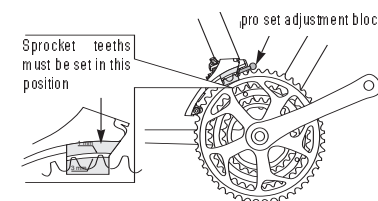

The derailleur must be adjusted as per illustration. The pro-set adjustment block may not be removed.

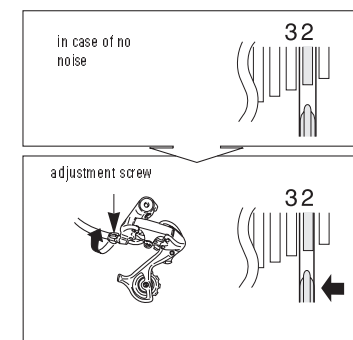

Loosen the adjustment screw until hearing a noise when the chain touch the third sprocket (counterclockwise).

## ADJUSTMENT OF THE FRONT DERAILLEUR

1. Mount the front derailleur on the seat tube (without chain) and turn it in a temporary position,
2. Check that the chain guide does not protrude beyond the largest chain wheel by more than 2 mm. The chain guide must not touch the chain wheels,
3. The chain guide must run parallel to the chain wheels. Check above,
4. Tighten the frame bolt and change to the smallest gear (smallest chain wheel, larger rear sprocket). In this position, the chain must almost run against the chain guide inner blade,
5. Tighten the front derailleur control cable and secure with the pinch bolt,
6. Change to the highest gear (largest chain wheel, smallest sprocket). In this position the chain must almost run against the chain guide outer plate of the right pedal crank,
7. Adjust both highest positions of the front derailleur with the adjusting screws,
8. Change the chain to the smallest and the largest gear. In both gears, the front derailleur must smoothly and immediately change the chain from the smallest to the largest chain wheel and vice versa.

### Note

This procedure applies for both two and three-ringed pedal cranks with round chain wheel.

### Caution!

To avoid excessive wear and damage of the chain, sprockets and chain wheels, we advise against the following combinations (see illustrations):

- Largest chain wheel – largest sprocket
- Smallest chain wheel – smallest sprocket

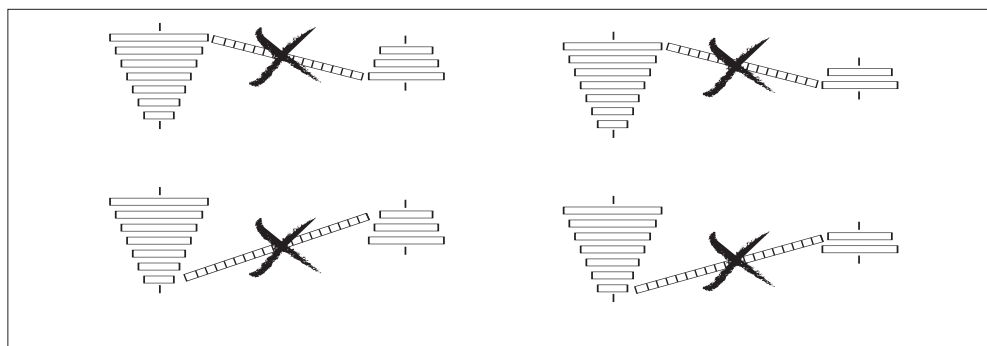

## CHAIN MAINTENANCE

Regularly check that your chain is clean and well-lubricated. Have your dealer check the chain for wear. Should you nevertheless want to check it yourself, you need to purchase the Rohloff Chain Caliber 2 from your Scott Dealer. This caliber will help you to work out whether your chain is too slack or not.

## OPERATION RAPIDFIRE PLUS SYSTEM

### Caution!

Do not press both right hand change control levers or both left hand change control levers at the same time. Damage to the change control may result.

### Rear lever Operation

For both lever A and lever B, the lever always returns to the initial position when it is released after changing.

### To change from a small sprocket to a larger sprocket

To change one gear step, press lever A to position 1; to change two, three or four gear steps at one time, press lever A to position 2, 3 or 4 respectively. A maximum of four step change can be operated in this manner.

### To change from a larger sprocket to a smaller sprocket

When lever B is pulled once and is then released, there is one step change from a large gear to a smaller gear.

### Front Lever operation

For both lever A and lever B, the lever always returns to the initial position when it is released after changing.

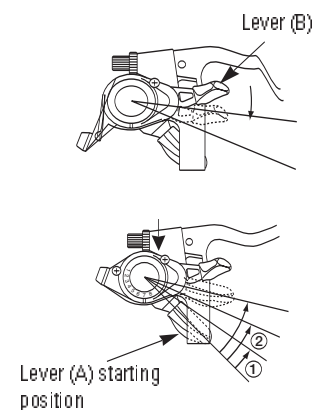

## OPERATION RAPIDFIRE PLUS SYSTEM

### To change from a small chain wheel to a larger chain wheel

As is shown in the illustration, when lever A is pressed to the mid-point of a full stroke, it clicks and there is a change (of one gear) from a small chain wheel to the next larger chain wheel.

**Example:** From the intermediate chain wheel to the largest chain wheel.

When the lever is pressed the full stroke (position 2), there is a change from the smallest to the largest chain wheel.

### To change from a large chain wheel to a smaller chain wheel

When lever B is pushed once, there is a one step change from a large chain wheel to a smaller chain wheel.

**Example:** From the largest chain wheel to the intermediate chain wheel.

### To shift from a small chainring to a larger chainring

When Lever (A) is pressed once, there is a shift of one step from a small chainring to a larger chainring.

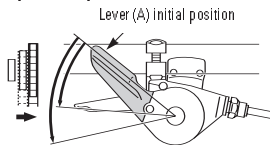

### To shift from a large chainring to a smaller chainring

When Lever (B) is pressed once, there is a shift of one step from a large chainring to a smaller chainring.

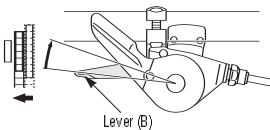

## OPERATION OF SHIMANO DUAL CONTROL SYSTEM

Lever A to change from a small sprocket to a larger sprocket.

Lever B to change from a large sprocket to a smaller sprocket.

Lever a to change from a small chain wheel to a larger chain wheel.

Lever b to change from a large chain wheel to a smaller chain wheel.

All levers return to the initial position when released.

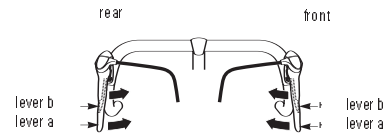

Lever A (to change from a small sprocket to a larger sprocket)  
Lever A has a click stop at positions 1, 2, and 3.

### Operation of rear derailleur lever

Lever A: Shifts from smaller to larger rear sprocket

Lever B: Stops at positions 1, 2 and 3

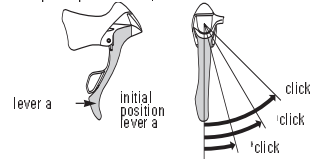

shift one gear to next bigger sprocket:  
Example: Change from 3rd to 4th gear

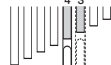

shift two gears to bigger sprocket:  
Example: Change from 3rd to 5th gear

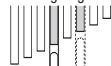

shift three gears to bigger sprocket:  
Example: Change from 3rd to 6th gear



## OPERATION OF SHIMANO DUAL CONTROL SYSTEM

1. To change one gear at a time. Example: from 3rd to 4th.

2. To change two gears at a time. Example: from 3rd to 5th.

3. To change three gears at a time. Example: from 3rd to 6th.

Lever a (to change from a small chain-ring to a larger chain-ring).

If operation of lever a does not complete the chain ring change stroke, operate lever A again for the distance "X".

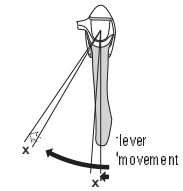

Lever b (to change from a large sprocket to a smaller sprocket). When lever B is pressed once, there is one step change from a large to a smaller sprocket).

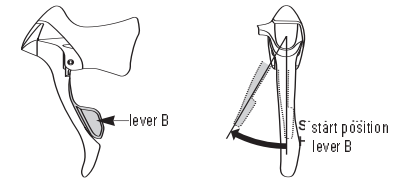

Lever B (to change from a large sprocket to a smaller sprocket). When lever B is pressed once, there is one step change from a large to a smaller sprocket).

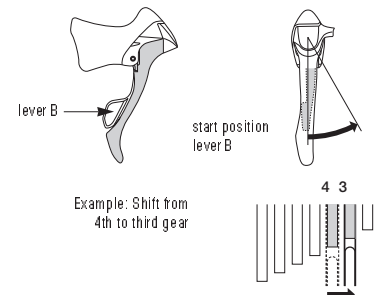

Example: Shift from 4th to third gear

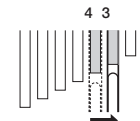



When lever b is operated, there is one click where trimming (the noise preventing mechanism) engages and a second stronger click when the gear change stroke is completed. After trimming, the next (light) push to the right will complete the gear change stroke to the smaller front chain-ring.

## TRIMMING (NOISE PREVENTION MECHANISM)

If the chain is on the largest chain wheel and the largest sprocket, the chain will rub against the front derailleur plate. When this occurs, press lever b to the point where it clicks, this causes the front derailleur to move slightly towards the smaller chain wheel, thereby eliminating the noise.

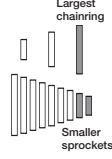
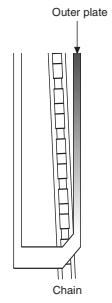
## TRIMMING (NOISE PREVENTION MECHANISM)

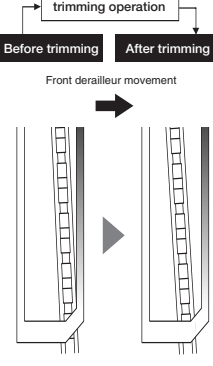
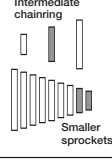
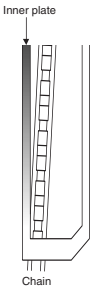
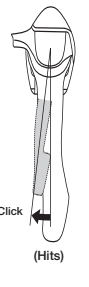
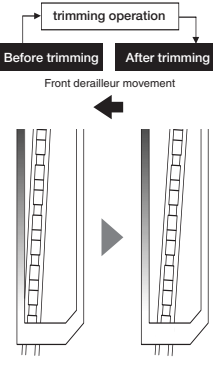
Chain position	Symptom	Trimming operation	
		Lever operation	Front derailleur movement
 <p>Largest chainring Smaller sprockets</p>	<p>Chain contacts outer plate</p>  <p>Outer plate</p> <p>Chain</p>	<p>Lever (a)</p>  <p>Click (Hits)</p>	<p>trimming operation</p> <p>Before trimming    After trimming</p> <p>Front derailleur movement</p> 
 <p>Intermediate chainring Smaller sprockets</p>	<p>Chain contacts inner plate</p>  <p>Inner plate</p> <p>Chain</p>	<p>Lever (b)</p>  <p>Click (Hits)</p>	<p>trimming operation</p> <p>Before trimming    After trimming</p> <p>Front derailleur movement</p> 

## BRAKES

### Brake adjustment general

Your Scott bike is fitted with a reliable and well-functioning braking system, provided the brakes are correctly adjusted. Check by measuring the distance between the brake shoes and the rim: it should be 1.5 to 2 mm.

Cable connection and adjustment of the (Dual Pivot) brake

1. Put the quick lever on the closed position.
2. Adjust the brake shoe clearance (as shown in the illustration) and secure the cable with the pinch bolt nut.

Cable bolt tightening torque 6-8 Nm

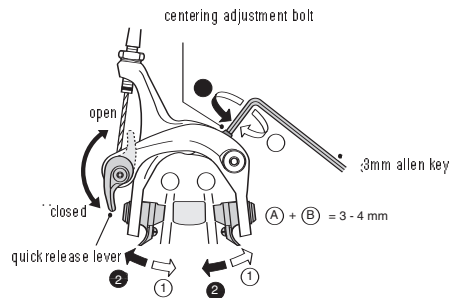

## CHANGE OF BRAKE PADS

1. Loosen up the security screw with a 2 mm allen key.
2. Push the used brake pad out of the aluminium brake shoe.
3. Push the new brake pad into the brake shoe, and beware of the arrow which shows the mounting direction.
4. Tighten up the security screw to approximately 1.5 Nm.

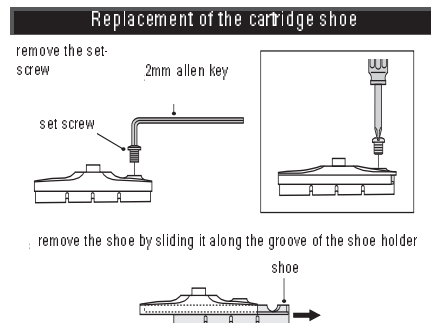

There are two different types of shoe and shoe holder to be used in the left and right positions respectively. Slide the new shoes into the grooves on the shoe holders while taking note of the correct directions and screw hole positions.

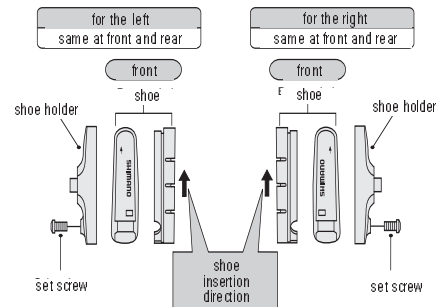

tighten the set screw

tightening torque: 1-1,5 Nm (9-13 in. lbs.)

## CENTRING THE BRAKE SHOE

Make a minor adjustment by using the centring adjustment screw.

### Readjustment of the brake shoe clearance

Turn the cable-adjustment bolt to readjust the brake shoe clearance.

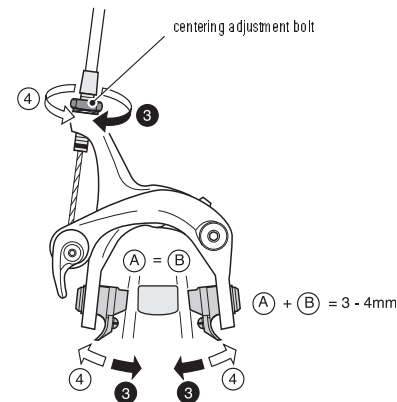

## V-BRAKES

### V-Brakes

1. While holding the shoe against the rim, tighten the shoe fixing nut.
2. Pass the inner cable through the inner cable lead, and after setting so that the total of the clearances between the left and right shoes and the rim is 2 mm tighten the cable fixing bolt.

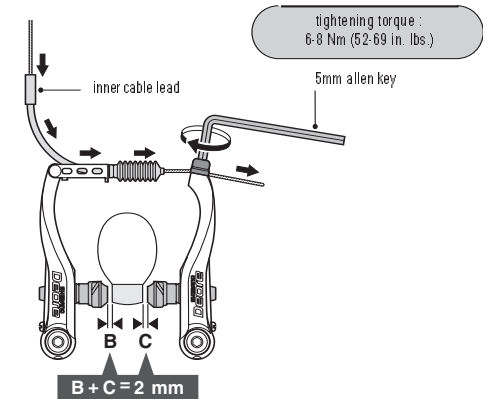

## V-BRAKES

- Slide the new pad into the shoe and make sure that the direction is correct and that the security pin holes concord.

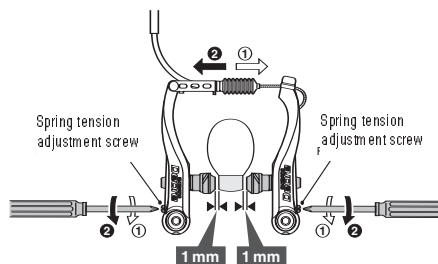

- The insertion of the security fixing pin is very important. It keeps the shoe properly in place

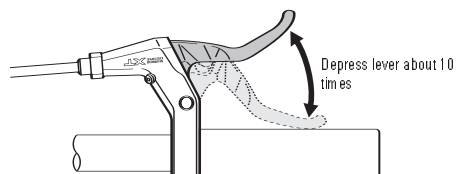

## REPLACEMENT OF THE BRAKE PADS/CARTRIDGE SHOE

Remove the security pin on the brake shoe.

- Remove the brake pad by sliding it along the groove of the brake shoe bar.
- Make sure to use the correct brake pad and brake shoe for each side. Those for the left side are different from those for the right side.
- Slide the new pad into the shoe and make sure that the direction is correct and that the security pin holes concord.
- The insertion of the security fixing pin is very important. It keeps the shoe properly in place

Remove the shoe fixing pin.

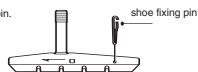

Remove the shoe by sliding it along the groove of the shoe holder.

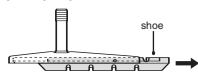

There are two different types of shoe and shoe holder to be used in the left and right positions respectively. Slide the new shoes into the grooves on the shoe holders while taking note of the correct directions and pin hole positions.

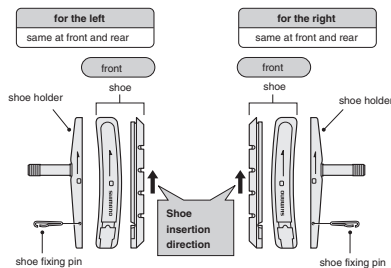

Insertion of shoe fixing pin is very critical to keep shoe properly fixed in place.

## DISC BRAKES

If your bike is equipped with disc brakes, please refer to the enclosed instructions of the manufacturer.

Please keep in mind that disc brakes need up to 30-100 brakings to reach maximum brake power.

### Reasons for the reduction of the braking effects

When sudden braking in bad weather conditions, there are risks of skidding. Even if this situation can be avoided, sudden braking will always happen. In this case, we recommend to apply the rear brake a little more than the front one.

### CAUTION!

Whatever the weather is like, you will never exclusively need the front brake; in order to prevent from sliding, you should always use both the front and the rear brakes together.

By wet weather, the braking distance is approximate 60 % longer than by dry weather.



## TIRES AND RIMS

Tires should always be inflated within the manufacturer's recommendations.

They are rated from 40 to 80 lbs. (check your tires).

Higher pressure for smoother roads or heavy riders.

Lower pressure for more shock absorption on rougher terrains.

Please find following example:

INFLATE TO MIN. 3.5 (50PSI) - MAX. 6.0 BAR (85PSI)



## RIM AND WEAR OF THE RIM

If the brake system has brake pads, you have to be aware of the fact that the rim will be worn through the action of braking.

When riding in wet and muddy terrain for example, the rim is quickly worn out.

**Small cracks in the brake surface of the rim or a deformation of the brake surface on the rim when increasing the tire pressure point out the end of the lifetime of the rim and the rim should be replaced immediately at an authorized dealer.**

Scott bikes that are fully equipped (lights, mudguard, carrier) have a wear-out indicator.

Please follow the instructions of the rim manufacturer shown in a manual or on the rim itself.



## WHEEL QUICK RELEASE

### Important:

**Riding with an improperly adjusted wheel quick release can allow the wheel to wobble or disengage from the bicycle, causing serious injury or death to the rider.**

Therefore, it is essential that you:

1. ask your dealer to help you make sure you know how to install and remove your wheels safely.
2. understand and apply the correct technique for clamping your wheel in place with a quick release
3. **each time, before you ride the bike, check that the wheel is securely clamped.**

The wheel quickrelease uses a cam action to clamp the bike's wheel in place. Because of its adjustable nature it is critical that you understand how it works, how to use it properly and how much force you need to apply to secure the wheel.

### Important:

**The full force of the cam action is needed to clamp the wheel securely. Holding the nut with one hand and turning the lever like a wing nut with the other hand until everything is as tight as you can get it will not clamp the wheel safely in the dropouts.**

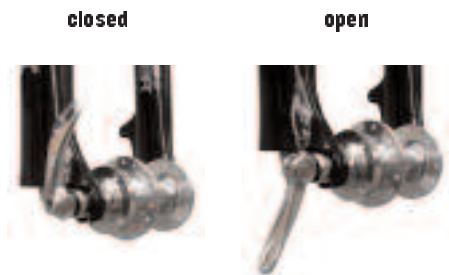

## ADJUSTING THE QUICK RELEASE MECHANISM

The wheel hub is clamped in place by the force of the quick release cam pushing against one dropout and pulling the tension adjusting nut, by way of the skewer, against the other dropout. The amount of clamping force is controlled by the tension adjusting nut. Turning the tension adjusting nut clockwise while keeping the cam lever from rotating increases clamping force; turning it counterclockwise while keeping the cam lever from rotating reduces clamping force. Less than half a turn of the tension adjusting nut can make the difference between safe clamping force and unsafe clamping force.

### Front Wheel Secondary Retention Devices

Most bicycles have front forks which utilize a secondary wheel retention device to keep the wheel from disengaging if the quick release is incorrectly adjusted. Secondary retention devices are not a substitute for correct quick release adjustment. Secondary retention devices fall into two basic categories:

- (1) The clip-on type is a part which the manufacturer adds to the front wheel hub or front fork.
  - (2) The integral type is molded, cast or machined into the outer faces of the front fork dropouts.
- Ask your dealer to explain the particular secondary retention device on your bike.

### WARNING!

Do not remove or disable the secondary retention device. As its name implies, it serves as a back-up for a critical adjustment. If the quickrelease is not adjusted correctly, the secondary retention device can reduce the risk of the wheel disengaging from the fork. Removing or disabling the secondary retention device may also void the warranty.

Secondary retention devices are not a substitute for correct quickrelease adjustment. Failure to properly adjust the quick release mechanism can cause the wheel to wobble or disengage, which could cause you to lose control and fall, resulting in serious injury or death.



### Removing a Quick Release Front Wheel

(1) If your bike has rim brakes, disengage the brake's quick-release mechanism to open the clearance between the tire and the brake pads (See Section 4.C fig. 11 through 15).

(2) Move the wheel's quick-release lever from the locked or CLOSED position to the OPEN position (figs. 7a & b).

(3) If your front fork does not have a secondary retention device go to step (5).

(4) If your front fork has a clip-on type secondary retention device, disengage it and go to step (5). If your front fork has an integral secondary retention device, loosen the tension adjusting nut enough to allow removing the wheel; then go to the next step.

(5) Raise the front wheel a few inches off the ground and tap the top of the wheel with the palm of your hand to knock the wheel out of the front fork.

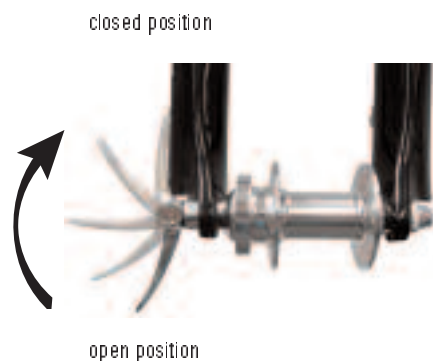

### Installing a Quick Release Front Wheel

#### CAUTION!

If your bike is equipped with disk brakes, be careful not to damage the disk, caliper or brake pads when re-inserting the disk into the caliper. Never activate a disk brake's control lever unless the disk is correctly inserted in the caliper. See also Section 4.C.



(1) Move the quickrelease lever so that it curves away from the wheel (fig. 7b). This is the OPEN position.

(2) With the steering fork facing forward, insert the wheel between the fork blades so that the axle seats firmly at the top of the slots which are at the tips of the fork blades — the fork dropouts. The quickrelease lever should be on the left side of the bicycle (fig. 7a & b). If your bike has a clip-on type secondary retention device, engage it.

(3) Holding the quick-release lever in the OPEN position with your right hand, tighten the tension adjusting nut with your left hand until it is finger tight against the fork dropout (fig. 6).

(4) While pushing the wheel firmly to the top of the slots in the fork dropouts, and at the same time centering the wheel rim in the fork, move the quickrelease lever upwards and swing it into the CLOSED position (fig. 6 & 7a). The lever should now be parallel to the fork blade and curved toward the wheel. To apply enough clamping force, you should have to wrap your fingers around the fork blade for leverage, and the lever should leave a clear imprint in the palm of your hand.

### FIX A FLAT TIRE

Bike tires are fitted with tubes.

Remove the wheel from the bike and deflate it. Unhook the tire from one side of the rim, using tire tools, not screw drivers.

Remove the tube from the tire casing, repair or replace it. Install the new or repaired tire. Fill the tube lightly with air in order to let it take its shape. Put the valve stem through the hole, and fit the inside tire. Put the tire bead in the rim starting at the valve and finishing at the opposite end, working on both sides. Push the valve stem into the tire and pull it back down to seat. Make sure the tube is not pinched under the tire bead. Inflate with hand or foot-pump.

### USE OF A BABY SEAT

Scott bikes of Racing Concept, Racing, Endurance, Progressive, Road, Roadster and Kids Series are not intended for the use of baby seats.

Please note that Scott will not take any warranty or responsibility when using a baby seat on bikes mentioned above.

There are too many different baby seat and baby seat fixation systems on the market to give a detailed table of systems that might fit without technical problems or endangering the passengers.

### USE OF A BICYCLE HAULER

Scott bikes are not intended for the use of haulers (load-haulers, kids-haulers, Trailer bikes).

Please note that Scott will not take any warranty or responsibility when using a hauler.

There are too many different haulers and hauler fixation systems on the market to give a detailed table of systems that might fit without technical problems or endangering the passengers.

### ASSIGNMENT OF BRAKE LEVERS TO FRONT AND REAR BRAKE

In general Scott bikes are delivered and preassembled with the right lever matching the rear brake and the left lever matching the front brake.

Due to national laws this could have been changed by your Scott dealer to fulfil the national laws.

Please ask your dealer to explain to you the assignment of the brakes and brake levers when handing over the bike.

## MAXIMUM WEIGHT AND LOAD OF SCOTT BIKES

**Scott mountain bikes** are intended for a maximum rider weight of 110 kgs, the overall weight of bike incl. rider should not exceed 119-128kgs (depending on bike weight).

**Scott trekking bikes** are intended for a maximum rider weight of 110 kgs, the overall weight of bike incl. rider and a maximum load of 25kgs should not exceed 143-150kgs (depending on bike weight).

**Scott road bikes** are intended for a maximum rider weight of 110 kgs, the overall weight of bike incl. rider should not exceed 117-120kgs (depending on bike weight).

**Scott kids** bikes are intended for a maximum load of 50 kgs including rider and load.

## USE OF SCOTT BIKES IN PUBLIC TRAFFIC

Please note and respect the national laws concerning the use of equipped and non-equipped bikes in public traffic.

This concerns e.g. reflectors and light systems.



## MAINTENANCE AND CARE

### Maintenance schedule

Please be aware of the fact that you have to follow the list of maximum tightening torques for screws at the end of this chapter.

### Please check before every ride:

- all bolts and nuts, especially the quickreleases of the wheels for proper fit and in case they are loose tighten them according to the maximum tightening torque.
- stem and handlebar for visible damages and replace them if necessary. Please make sure that the bolts are tightened evenly when closing the front cap, according to the tightening torque recommended by the producer of the parts
- Braking systems
- Air pressure of the tires according to the recommendation of the producer.
- Light systems and bell
- Handlebar grips to be fixed to the handlebar
- All parts of the rear suspension system including mounting bolts
- The front suspension fork on perfect function and play in the bushings.

## PLEASE CHECK ADDITIONALLY MONTHLY

- front and rear derailleur for perfect function and grease them. If necessary readjust the system and clean it.
- the play of the headset. If necessary readjust it.
- Brake and shifting cables on perfect wear and leakage on hydraulic systems. If necessary grease the cables.

## PLEASE CHECK IF NECESSARY OR AT LEAST ONCE A YEAR AT YOUR LOCAL DEALER

- chain wear and tension ( on bikes equipped with internal gear hubs). Readjust if necessary, clean and grease the chain.
- Bottom bracket cartridge for play, if necessary replace it.
- Pedal bearings for play, if necessary replace them.
- front and rear derailleur for perfect function and grease them. If necessary readjust the system and clean it.
- stem and handlebar for visible damages and replace them if necessary. Please make sure that the bolts are tightened evenly when closing the front cap, according to the tightening torque recommended by the producer of the parts.
- Complete brake system on perfect function and readjust and grease it if necessary. Replace worn out or defective parts. Replace leaking hydraulic pipelines at once .
- Rims and tension of spokes. If necessary true them.
- Air pressure of the tires according to the recommendation of the producer.
- Overall condition of the tires
- Light systems and bell
- Handlebar grips to be fixed to the handlebar
- All parts of the rear suspension system including mounting bolts
- The front suspension fork on perfect function and play in the bushings.
- Frame and fork on perfect condition, replace in case of damages

## SPARE PARTS FOR YOUR SCOTT BIKE

**For buying spare parts we strongly recommend to visit your local Scott dealer as he knows best which parts will fit to your bike and can help you to make your choice of parts matching to your bike.**

**By doing so, you can avoid a combination of parts that might not match to each other.**

**Please only use original spare parts as only these can guarantee optimum function and safety while riding.**

**This is extremely important on parts of the brake system, the tire and air tube.**

**Please note that Scott is not responsible for damages caused by not using original spare parts.**

**Never use adapter solutions to fix or assemble brakes, seat/seatpost and stem/handle bar!**



## BICYCLE CARE

In order to keep the function and optic of the bike in good condition we recommend periodical bicycle care.

Doing so keeps the value of the bike and helps to prevent from corrosion or other damages:

- clean with soft brush, water and soft towel. Do not use high pressure cleaner, otherwise bearings, color or decals can be damaged.
- Do not use aggressive cleaning additives
- Repair color damages at once
- Grease or oil all metal parts especially during winter use

**Please use biodegradable bicycle cleaners and degreasers which are offered at your local dealer.**

## TIGHTENING TORQUES FOR SCOTT BIKES

Rear Derailleur	Mounting bolt	7.8-9.8 Nm
	Cable fixing bolt	3.9-5.9 Nm
	Pulleys screws	2.9-3.9 Nm
Front Derailleur	Clamp	4.9-6.8 Nm
	Cable fixing bolt	4.9-6.8 Nm
Rapidfire lever	Clamp mounting bolt	4.9-6.8 Nm
STI	Clamp mounting bolt	4.9-6.8 Nm
Brake lever	Clamp mounting bolt	4.9-6.8 Nm
Freewheel hub	Freewheel body	35-49 Nm
	Cassette fixing nut	30-49 Nm
Crankset	Square type	35-45 Nm
	Spline type	35-50 Nm
	Chainring screws	7.8-10.7 Nm
BB- Cartridge		50-70 Nm
Pedals		40 Nm
Stem	Mounting bolts M5	5.6-7.8 Nm
	M6	9.8-13.7 Nm
Seatpost-seatclamp	M4	2.9-3.9 Nm
	M5	5.6-7.8 Nm
	M6	9.8-13.7 Nm
V-Brake	Frame mounting bolts	5-6.8 Nm
	Cable fixing bolt	5.8-7.8 Nm
	Brake pad bolts	5-6.8 Nm
Caliper Disc brake	Magura	6 Nm
	Shimano	6-8 Nm
	Formula	9 Nm
	Hayes	12 Nm
Disc mounting bolts	Magura	4 Nm
	Shimano	2-4 Nm
	Formula	6.2 Nm
	Hayes	5 Nm
Swingarm pivot bolts	Strike, G-Zero, Octane up from 2000,	5 Nm
	High Octane	
	Intoxica	5.5 Nm
	Octane up to 99	5.5 Nm
	Tacoma	5.5 Nm
Rear shock mounting bolts	Strike, G-Zero, Octane up from 2000,	8 Nm
	High Octane	
	Intoxica	8 Nm
	Octane up to 99	8 Nm
	Tacoma	8 Nm
Replaceable Drop out	All models	7.8-10.7 Nm

## TROUBLESHOOTING

Trouble	Reason	Solution
Fork shakes	headset loose	tighten and lock
Chain pops out	derailleurs not adjusted chainwheel bent	adjust acc. to manual fix or change
bearings squeak or crack	bottom bracket pedals need grease hubs need grease	replacement dismount, clean, grease dismount, clean, grease
bearings are loose	bottom bracket pedals hubs	replacement tighten and lock tighten and lock
handlebar cracks, shakes	stem or handlebar bolts are or turns	tighten all bolts and nuts loose
seat post turns or slides	- quick release is loose - seat post too thin diameter	retighten and lock check diameter
front derailleur rattles	bottom bracket loose not adjusted chainwheel bent	tighten adjust BB fix or change
suspension fork is loose		contact your local dealer
rear suspension is loose		contact your local dealer

## 11. WARRANTY

SCOTT bikes are made using the most innovative production and quality methods. They are equipped with best components of well known parts suppliers.

Doing so SCOTT warrants its hardtail frames – full-suspension bikes excluded – for three years, its frames and swingarms of fullsuspension bikes for two years and SCOTT forks (provided it is a fork of SCOTT) for two years for defects in material and/or workmanship in case of purchase of completely assembled new bikes. Further warranties are additionally granted for certain models according to their respective manual. The warranty period starts at the day of purchase.

This warranty is limited to the first buyer, what means the first person who uses the bike and only with the use it was made for. The bike is to purchase via authorized SCOTT-dealers to the exclusion of purchases via internet auctions.

In case of a warranty claim the decision to repair or to replace the defective part is up to SCOTT. Non defective parts will only be replaced at the guarantee's own expense.

Fair wear and tear is not covered by the warranty. A complete list of all parts of wear and tear and a description of all wear characteristics can be found in the next chapter of this manual.

In addition, you will find at the end of this manual a protocol for the handing over of the bike which will remain in copy at the SCOTT dealer after acceptance and signature of the consumer.

It is obligatory to show this protocol of handing over together with the bike or the defective part in case of a warranty claim given that it provides evidence of purchase. Otherwise no warranty is granted.

Claims must be made directly through an authorized dealer with the protocol of handing over. For information regarding the nearest dealer, write or call this company or the national SCOTT distributor.

Normal wear, accident, neglect, abuse, improper assembly, improper maintenance by other than an authorized dealer or use of parts or devices not consistent with the use originally intended for the bicycle as sold (races, freestyle, stunts) are not covered by this warranty.

Under reservation of national warrant of merchantability.

## PARTS OF WEAR AND TEAR

### Chain

Due to its use the chain is subject to wear and tear. This depends on maintenance and conditions of use of the bike (amount of kilometers, rain, dirt, salt, etc.).

Cleaning and greasing will help to prolong its life but you will have to replace the chain when reaching the wear limit.

### Sprockets, chainrings and pulleys

Due to its use sprockets, chainrings and pulleys are subject to wear and tear.

This depends on maintenance and conditions of use of the bike (amount of kilometers, rain, dirt, salt, etc.).

Cleaning and greasing will help to prolong its life but you will have to replace the chain when reaching the wear limit.

### Shifting and brake cables

All cables must be surveyed regularly and changed if necessary. This can happen especially when the bike is often standing outside in weather.

### Brake pads

All brake pads, no matter if rim-brake, disc-brake or internal brake are subject to wear and tear due to their use.

This depends on maintenance and conditions of use of the bike (amount of kilometers, rain, dirt, salt, etc.). Check your brake pads regularly and replace them if necessary.

### Rims

When using a rim brake not only the brake pads are subject to wear and tear. Also the rim.

Because of this please check regularly the rims e.g. when inflating the tires.

In case of small cracks or deformation of the brake surface of the rim while inflating the tires replace the rim immediately.

Rims with wear-out indicators enable the bike user to check easily the condition of the rim. Please have a look concerning this issue on the sticker on the rim.

### Tires

Due to their use tires are subject to wear and tear. This depends on the use of the bike and is influenced by the riding style.

Aggressive braking will reduce the lifetime of the tire dramatically.

In addition check the air pressure regularly and inflate the tire according to the pressure recommended by the producer of the tire which is imprinted on the sidewall of the tire.

## PARTS OF WEAR AND TEAR

### Light Systems and reflectors

A well functioning light system is of a very high importance for your riding safety in public traffic. Before every ride check front and tail light and the condition of the reflectors. Light bulbs are subject of wear and tear and we recommend to take some replacements with you in case of failure.

### Handlebar grips

Due to their use handlebar grips are subject to wear and tear, and should be replaced immediately in case they do not fit anymore to the handlebar or get loosen.

### Handlebar, stem and seat post

Handlebar, stem and seat post are under high dynamic forces while riding. Please check these parts regularly for visible cracks or damages and replace them if necessary. In addition we recommend a periodical replacement (every two years) of these parts when riding often and hard.

## PROTOCOL FOR HANDING OVER

### SCOTT Dealer

Address .....  
Telephone/Fax/ e-mail: .....

### Consumer

Name .....  
Address .....  
Telephone/Fax/ e-mail: .....

Product .....  
Model .....  
Date of delivery : .....

### Confirmation

- The product named above was checked detailed by myself.
- The delivery took place completely and without any visible defects.  
Notes : .....
- The owner's manual was handed over and I got a detailed oral information about its content.
- I'm aware that the duty for the implied warranty of the retailer is limited to faulty products. There is no warranty for damages of wear and tear which are caused by using the product, especially when they must be seen as normal wear and tear.

.....  
Place/ date Consumer's signature

