

## «SAG-BOY»

The length of the grey beam shows the optimum eye-to-eye distance of the rear shocks.

**Der graue Balken zeigt den optimalen Bolzenabstand des Dämpfers.**

La longueur de la barre grise représente l'écart optimal entre les points de fixation de l'amortisseur.

OWNERS MANUAL  
BEDIENUNGSANLEITUNG  
MANUEL D'UTILISATION



Scott Sports SA  
Route du Crochet 17  
1762 Givisiez / Switzerland

[www.scott-sports.com](http://www.scott-sports.com)



2007  BIKE  
OWNERS  
MANUAL

P



The Reflex FX should be adjusted exactly to the current rider for reaching maximum safety and fun while riding.

All adjustments should be done at the local Scott dealer or following this manual.

## CONTENT

> Reflex-Concept / Characteristics	Page 2
> Kinematics	Page 2
> Shock-Technology	Page 3
> Set-Up Reflex FX	Page 3
> SCOTT Smart Cable Routing	Page 4
> Front Fork Set-Up	Page 5
> Pivot Maintenance	Page 5
> Warranty	Page 6/7

## REFLEX-CONCEPT / CHARACTERISTICS

Reflex is based on the results of research and development of the very successful Scott Genius-Series, not only looking for a lightweight frame but also for an innovative suspension technology in combination with an optimized kinematics of the rear swingarm.

The combination of an optimized kinematics with a revolutionary suspension technology closes the gap between hardtail bikes and the new generation of full suspended bikes with automatic lockout systems which are already on the market and which are still a compromise between suspended and non suspended bikes.

Reflex was designed for riders and enthusiasts looking for a "non-bobbing" hardtail-like power transfer to the rear wheel but are not willing to give up the benefits of a full suspended bike.

Scott does not see frame, rear shock and kinematics as single components which are assembled together on a bike, but as a concept with all these components working together and offering an outrageous function by matching perfectly.

## KINEMATICS

The Reflex Concept is based on a new designed multi-pivot technology having no fixed swingarm pivot but moving on a virtual pivot line.

The more the weight of the rider gets on the rear wheel (going uphill) and with this the SAG (negative travel) getting bigger, the more the pivot is moving towards the small chainring.

In combination with the linear and at the end of stroke progressive shock characteristics the chain tension will be reduced and doing so the pedaling will not influence function or movement of the rear swingarm.

Scott Intelligent Linkage System (ILS) eliminates the troublesome bobbing.

No power will be lost and an optimum power transfer is guaranteed as the swingarm, in contrary to locked or automatic-locking systems, can follow the trail surface and will offer perfect traction and higher speed.

## SHOCK-TECHNOLOGY

The heart of the LC-R-System is the newly developed and innovative Scott Genius LC-R Shock, offering two functions:

By using the lock out lever on top of the shock body you can choose between following functions:

1. **ALL TRAVEL MODE:** full travel of 100mm on Reflex FX models.
2. **LOCK OUT MODE:** the shock is locked; climbing on asphalt roads is now possible without any power loss. Simultaneously a blow-off-system prevents the shock being damaged in case the rider did not open the system while crossing obstacles. [1]

## SET-UP REFLEX FX

The Set-Up of the Genius LC-R Shock is shown in the manual "Scott Genius TC+LC-R Shock 07" attached to this bike and can be done within a few minutes. [2]

2



Genius Shock Manual

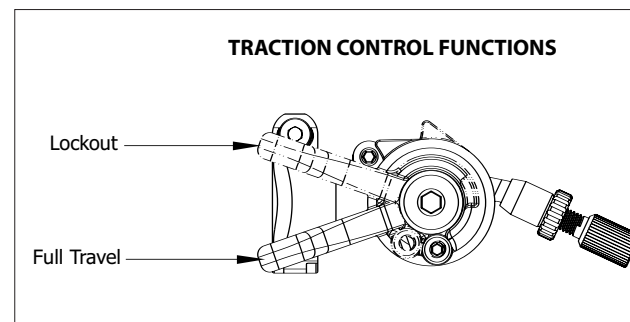

## SCOTT SMART CABLE ROUTING

The direct and straight cable system on all our full suspension models allows Smart Cable Routing which is very resistant against water and dirt.

To change the cables simply unscrew and open the three cable brackets on the downtube.

On the left side of the downtube you will find the cable housings of the rear brake and on the right side for the rear derailleur. **[3]**

3



Smart Cable Routing

## MECHANICS HINT

The outer housing of the cables can also be fixed on the bottle cage with cable fixers, the two brackets below the cage are not needed anymore. **[4]**

4



Mechanics hint

## FRONT FORK SET UP

For the set up of the front fork please use the fork specific manual attached to the bike .

## PIVOT MAINTENANCE

The pivot and bearings on SCOTT Reflex FX are extremely easy to maintain.

An external treatment with a grease spray after every bike wash is all you have to do. We do not recommend heavy grease sprays since these will leave a film on the parts which is difficult to remove. We recommend the same for the chain also.

If you have to change the bearings you can order them included in a service kit at your local SCOTT dealer with parts number 15.5.860.503.0.000.

In case of a change of the bearings or of the rear swingarm you should contact your local SCOTT dealer therefore you need special tools for disassembly and assembly.

## WARRANTY

**Model** \_\_\_\_\_

**Year** \_\_\_\_\_

**Size** \_\_\_\_\_

**Frame** \_\_\_\_\_

## WARRANTY

SCOTT bikes are made using the most innovative production and quality methods. They are equipped with best components of well known parts suppliers.

Doing so SCOTT warrants its frames and swingarms for five years (subject to compliance with maintenance ranges, see below) and SCOTT forks (provided it is a fork of SCOTT) for two years for defects in material and/or workmanship in case of purchase of completely assembled bikes.

This warranty of 5 years for the frames shall only be granted in case once a year a maintenance service has been effected according to maintenance requirements as set forth in this manual by an authorised SCOTT dealer.

The authorised SCOTT dealer shall confirm the effected annual maintenance service by stamp and signature.

In case such an annual maintenance service has not been effected the warranty of 5 years for the frame shall be reduced to 3 years.

Costs for maintenance and service have to be born by the owner of the SCOTT bike.

On High Octane the warranty period is limited to 2 years.

The warranty period starts at the day of purchase.

This warranty is limited to the first buyer, what means the first person who uses the bike and only with the use it was made for. Furthermore, this warranty is limited to purchases via authorized SCOTT-dealers to the exclusion of purchases via internet auctions.

In case of a warranty claim the decision to repair or to replace the defective part is up to SCOTT. Non defective parts will only be replaced at the guarantee's own expense.

Fair wear and tear is not covered by the warranty. A complete list of all parts of wear and tear can be found in the next chapter of this manual.

In addition, you will find at the end of this manual a protocol for the handing over of the bike which will remain in copy at the SCOTT dealer after acceptance and signature of the consumer.

It is obligatory to show this protocol of handing over together with the defective part in case of a warranty claim given that it provides evidence of purchase. Otherwise no warranty is granted.

In principle, this warranty is granted worldwide. Claims must be made through an authorized dealer, for information regarding the nearest dealer, write or call this company or the national SCOTT distributor.

Normal wear, accident, neglect, abuse, improper assembly, improper maintenance by other than an authorized dealer or use of parts or devices not consistent with the use originally intended for the bicycle as sold are not covered by this warranty.

Hereby SCOTT grants a voluntarily manufacturer's warranty. Additional entitlements according to national warrant of merchantability are reserved.