

SCOTT-SPORTS.COM

SCOTT
BIKE OWNERS MANUAL
OWNERS MANUAL / BEDIENUNGSANLEITUNG / MANUEL D'UTILISATION

EQUALIZER

SAG-BOY

The lengths of the grey beam shows the optimum eye-to-eye distance of the rear shock.
 Der graue Balken zeigt den optimalen Bolzenabstand des Dämpfers.
 La longueur de la barre grise représente l'écart optimal entre les points de fixation de l'amortisseur



The basic set-up of a Scott Equalizer TC Shock is easy and can be done within a few minutes.

The Scott Equalizer TC Shock should be adjusted exactly to the current rider for reaching maximum safety and fun while riding.

All adjustments should be done at the local dealer or following this manual.

CONTENT

> Traction Control-Functions	P. 02
> Power Stabilizer	P. 02
> Intelligent Rebound Valve	P. 03
> Oil Transfer Shock	P. 03
> Picture of the Equalizer TC Shock and Remote Control Lever	P. 04
> Basic Set-Up of the Remote Control Equalizer TC Shock	P. 05
> Mount of the remote control of Equalizer TC Shock	P. 05
> Recommended Tools for the Shock Set-Up	P. 06
> Set-Up of Positive Air Chamber Equalizer TC Shock	P. 07
> Set-Up of Negative Air Chamber Equalizer TC Shock	P. 07
> Set-Up of Rebound Equalizer TC Shock	P. 08
> More Details about Shock Set-Up Equalizer TC Shock	P. 09
> Maintenance / Service Guide	P. 09
> Warranty	P. 12/13



TRACTION CONTROL-FUNCTIONS

The heart of the TC-System is the newly developed and innovative Scott Equalizer TC Shock, offering three functions which make this system possible.

By using the remote lever you can choose between following functions:

1. ALL TRAVEL MODE: full travel of 165mm
2. TRACTION MODE: by reducing the chamber volume inside the shock the travel of the shock will be reduced to around 60% (approx. 100mm), the characteristic of the air spring gets harder. This results in climbing without "bobbing" and offers still optimum traction of the rear wheel.
3. LOCK OUT MODE: the shock is locked, climbing on asphalt roads is now possible without any power loss. Simultaneously a blow-off-system prevents the shock being damaged in case the rider did not open the system while crossing obstacles.

You will find following positions on the remote lever. **[1]**

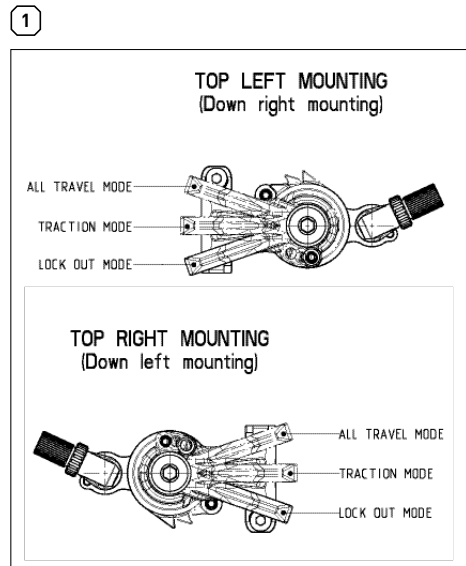

remote lever

The Power Stabilizer is a option to ride with or without Pedal Platform by just tapping one button on the shock.

By pulling the rebound adjuster knob upward you switch on the pedal platform for a better climbing without bobbing when standing on the pedals..

By pushing the rebound adjuster knob downward you switch off the pedal platform for a supple break away. **[2]**

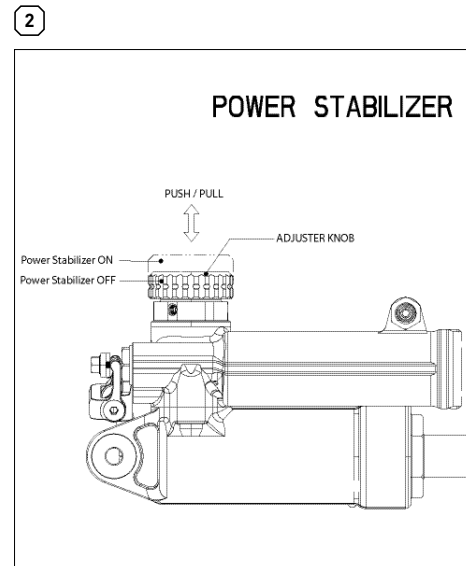

rebound knob/ps knob

INTELLIGENT REBOUND VALVE

Scott found a revolutionary way to design a valve that adjusts itself by the speed of impact on the rebound motion.

In contrary to conventional systems our new designed Intelligent Rebound Valve system can distinguish if the shock should rebound fast or slow.

On small impacts the system stays fully active and reacts with a fast rebound.

After a jump or big impacts/grooves the rebound is slowed down automatically. Doing so, the kick back of the saddle that results from too fast rebound, is eliminated.

OIL TRANSFER SHOCK

In contrary to conventional systems which have the piston with compression and rebound shim stack moving in an oil bath, our new developed OTS-system pushes the oil through a fixed piston from one oil chamber to another.

By using this fixed piston Scott was able to integrate more functions (e.g. Power Stabilizer, Intelligent Rebound Valve) beside the standard compression/ rebound adjustment devices.

In addition the shock works with a bigger volume of oil which results in a bigger heat resistance and a reduced wear and tear of the oil.



EQUALIZER TC SHOCK AND REMOTE CONTROL LEVER

In the drawing of the shock and remote lever, shown below, you will see the parts indicated with numbers which will be used in the manual for the adjustment and set-up.

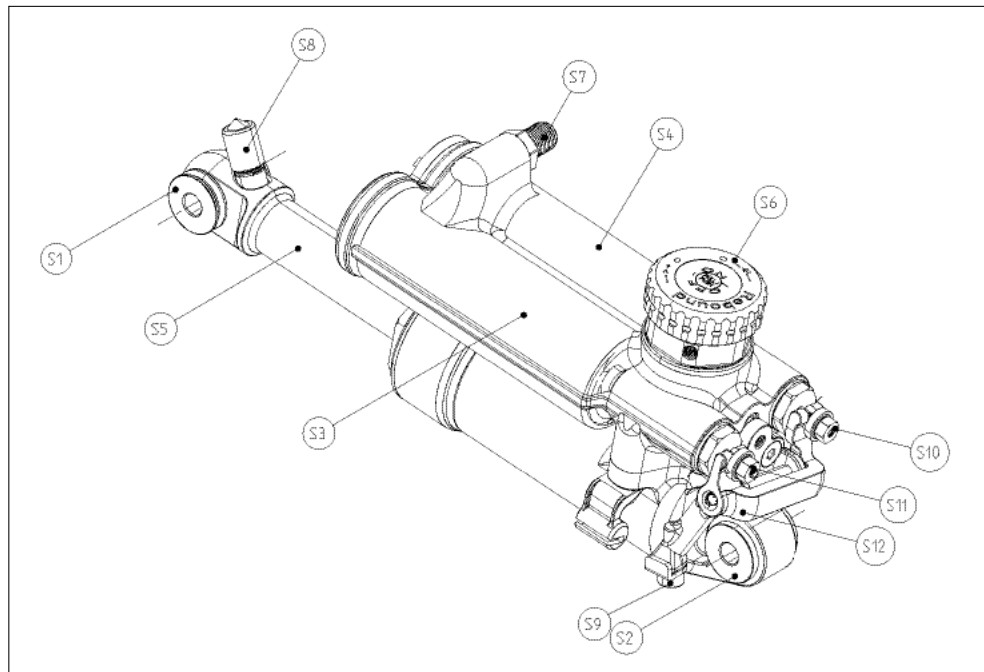

S1	Upper Shock Bolt	S10	Traction Mode Pin
S2	Lower Shock Bolt	S11	Lock Out Pin
S3	Left Piggy-Back	S12	Mode Lever
S4	Right Piggy-Back	L1	Remote Lever
S5	Shock Piston	L2	Remote Control Cable
S6	Rebound Adjuster/Power Stabilizer Knob	L3	Tension Screw
S7	Positive Chamber Valve	L4	Allen Screw
S8	Negative Chamber Valve	L5	Allen Screw
S9	Remote Cable Fixation Screw	L6	Cable Guide Hanger

BASIC SET-UP OF THE REMOTE CONTROL OF EQUALIZER TC SHOCK

1. Put the remote lever (L1) to position "lock-out"
2. Fix the remote control cable (L2) with the cable fixation screw (S9) using a 3mm allen key (tightening torque: 3 Nm) on the Mode Lever (S12)
3. Put the remote lever now to position "Traction Mode" The Lock Out Pin (S11) should be pulled out approx. 1mm.
4. When putting now the remote lever to position "All Travel" the cable will pull the Mode Lever (S12) including the Traction Mode Pin (S10) and the shock will offer now the full travel.
5. Check now the set-up for perfect function of remote lever and shock
6. In case you want to fine-tune the brake-away power of the remote lever, you can do this by using a 2mm allen key and by turning the allen screw (L4). In case you want to readjust the tension of the remote control cable you can do this by using the tension screw (L3). **[1]**

1

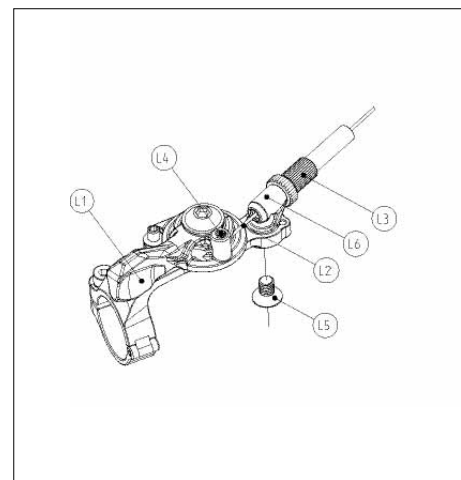

MOUNT OF THE REMOTE CONTROL OF EQUALIZER TC SHOCK

To switch the TC2 Lever from one side of the bar to the other one, please proceed as explained below:

[2] [3]

1. Remove the inner cable from the system as shown in the Equalizer TC manual
2. Unscrew the clamp fixing screw on the bar clamp with a 3 mm Allen key
3. Unscrew screw L1 by using a 3mm Allen key
4. Take the cable guide assembly (L2 + L3 + L4) away
5. Unscrew screw L5 with a 2 mm allen key
6. Unscrew the main screw L8 with a 4 mm allen key
7. Lift parts L8, L9 (2x) and L10. Take the spring L6 and the ball L7 out of the assembly. Pay attention not to loose them.
8. Remove screw L12 with 1.5mm allen key
9. Loosen base plate fixing screw L11 with a 3 mm allen key
10. Turn index plate L13 to the position of your choice (turn it of 180° for left or right position), see detail pictures.

2

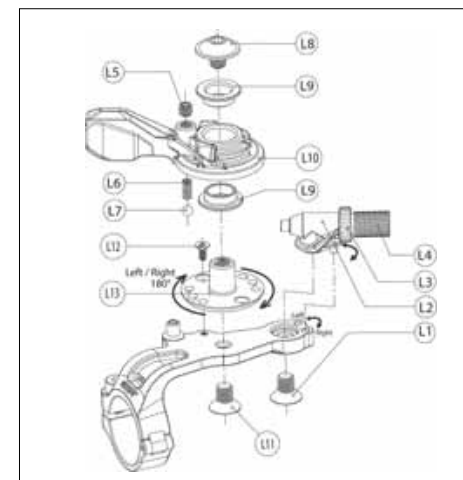

MOUNT OF THE REMOTE CONTROL OF EQUALIZER TC SHOCK

11. Refix screw L12 with 3 Nm (27 in - lbs)
12. Refix screw L11 with 5Nm (44in - lbs)
13. Reassemble parts L8, L9 (2x) and L10 .
14. Tighten screw L8 with 5 N m (44in - lbs)
15. Insert the index ball L7 and the spring L6 in the hole of the lever L10. Make sure that the ball fits exactly in one of the 3 grooves of index plate L13 (if necessary, turn the lever L10 to reach one of these positions)
16. Insert screw L5 (just tighten it until 2mm of its thread are in the lever L10)
17. Position the cable guide assembly (L2+ L3 + L4) : put the pin on the downside of L2 into the hole corresponding to the side of bar you want to put the lever (see picture)
18. Tighten screw L1 with a tightening torque of 5Nm (44in - lbs)
19. Double check the position of the lever parts in combination to the bar - side by comparing the visible side indication on the downside of index plate L13 as shown on detail pictures (Bottom view).
20. Fix the lever on the bar by screwing the clamp fixing screw of the lever clamp with 5 N m (44in - lbs)
21. Insert the cable
22. Fix the cable on your shock (see Equalizer TC manual).
23. Adjust the index force of your lever by screwing/unscrewing screw L5 until you reach the break - away force of lever L10 of your choice.

RECOMMENDED TOOLS FOR THE SHOCK SET-UP

For the set-up of the shock we recommend to use the tools listed below:

- a shock pump with a scale up to 30 bars/435 psi with a special air valve connector preventing from air getting away while removing the pump from the shock valve, this will result in an exact air pressure. Therefore we strongly recommend the use of the Scott Shock Pump which is attached to your bike
- the SAG-Boy on the back of this manual

3

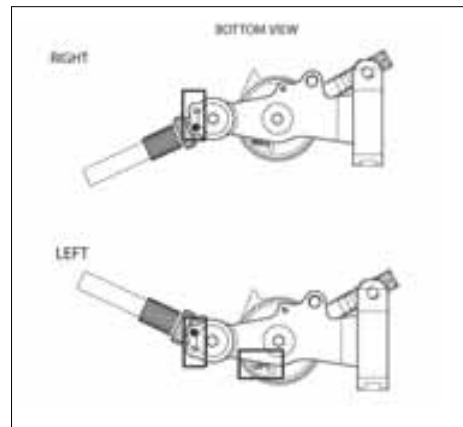

SET-UP OF POSITIVE AIR CHAMBER EQUALIZER TC SHOCK

The positive air chamber contains the air-spring you "sit-on" while riding.



Important: For all adjustments of the air spring the remote lever has to be in the "all travel" position.

To adjust the air pressure of the positive chamber of the Scott Equalizer TC Shock please refer to the following instruction:

1. remove the valve cap of the black valve (S7) located on the Left Piggy-Back (S3).
2. mount the shock pump with its adaptor on the valve
3. pump the recommended pressure into the shock. On the inner side of the seatstays you will find a table showing in the black colored areas the recommended air pressure of the positive chamber according to the rider's weight.
4. when you reached the needed pressure remove the pump and put the valve cap on the valve

rider weight kg	lb	- air setting		+ air setting	
		bar	psi	bar	psi
60	132	20	290	20	290
65	143	21.3	309	21.3	309
70	154	22.6	328	22.6	328
75	165	23.9	347	23.9	347
80	176	25.3	367	25.3	367
85	187	26.6	386	26.6	386
90	198	27.9	405	27.9	405

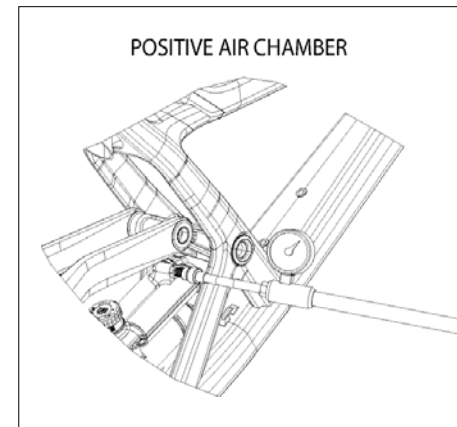

SET-UP OF NEGATIVE AIR CHAMBER EQUALIZER TC SHOCK



Important: Remove the pump before testing the shock.

The negative air chamber contains the air-spring influencing the brake-away and characteristic while absorbing shocks. A too high brake-away can cause a non-secure and uncomfortable ride.

To adjust the air pressure of the negative chamber of the Scott Equalizer TC Shock please refer to the following instruction:

1. Remove the cap of the silver valve (S8) located on the Shock Piston (S5)
2. Mount the shock pump with its adaptor on the valve
3. Pump the same pressure you have used for the positive chamber into the negative chamber.
4. When you reached the needed pressure remove the pump and put the valve cap on the valve.

We recommend making sure that the pressure balance between positive and negative chamber follows this manual.

Not doing so may cause a loss in performance or comfort or may result in damage of the shock. After adjusting positive and negative chamber according to the rider's weight you can double check by using the SAG-Boy, which is on the back of the manual, if the SAG (negative travel) is well adjusted.

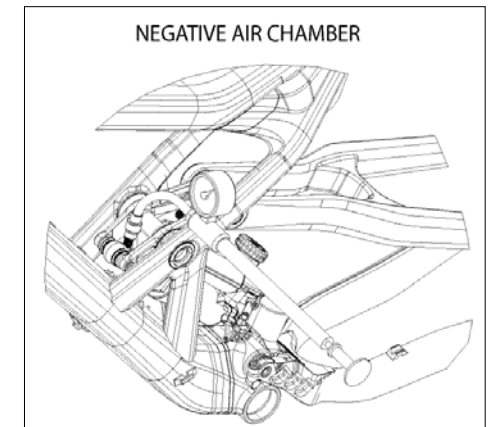

SET-UP OF REBOUND EQUALIZER TC SHOCK

The negative travel is important when crossing grooves or holes on the trail.

If the bike is well adjusted the rear wheel and the swing-arm will roll through the groove without the mainframe moving.

The SAG should be 15-20% of the travel for race oriented riders and 20-25% of the travel for comfort oriented riders.

The SAG-Boy indicates the recommended eye-to-eye distance of the shock bolts of the Ransom models.

To check the adjustment, please follow as shown below:

1. sit on the bike, put your feet on the pedal
2. ask a second person, to put the color beam of the SAG-Boy, recommended for your bike model, aside the eye-to-eye distance of the shock bolts. - if the distance between the bolts is corresponding to the length of the color beam, the air pressure is matching to your weight
 - if the distance between the bolts is longer than the length of the color beam, the air pressure of the positive chamber is too high and should be carefully reduced by using the bleed knob of the shock pump until the measures are corresponding
 - if the distance between the bolts is shorter than the length of the color beam, the air pressure of the positive chamber is too low and should be increased by using the shock pump until the measures are the same.

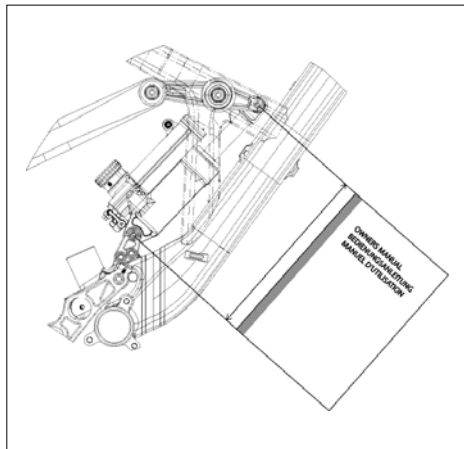

"Rebound" describes the speed the shock comes back to its original length after absorbing an obstacle.

By using the red rebound screw (S6) you can adjust the rebound step by step.

Please refer to the following instruction:

Ride your bike off a pavement (remain in the saddle) and check how many times it bounces.

- if it bounces 1-2 times, the set up is good.
- If it bounces more than 3 times the rebound is too fast. Turn the screw 1-2 "clicks" clockwise
- If it does not bounce the rebound is too slow. Turn the screw 1-2 "clicks" counter clockwise.

MORE DETAILS ABOUT EQUALIZER TC SHOCK SET-UP

In case you want more exact numbers of the shock air pressure than shown on the decal on the frame or you're looking for tuning hints including different shock characteristics of the Equalizer TC Shock, please have a look at

www.scott-sports.com

In addition you can download this tuning program on your pc.

MAINTENANCE / SERVICE GUIDE

Please clean regularly after riding off-road the shock piston and all other parts in motion of the shock with a soft and wet cloth or if needed with mild soap to prevent from excessive wear and tear.

For maintenance and service please refer to the following table:

Maintenance period	New	Every ride	Every 8 hours	Every 40 hours	Every 1000 hours / min. 1 x year
Check of air pressure	×	×			
Check of rebound	×	×			
Clean shock bushings, check for tear and wear, grease				×	
Change of oil/inspection at Scott Shock Service					×
Clean shock housing		×			
Clean Lockout mechanism		×			





Important:

The Scott Equalizer TC Shock is pressurised.
Never open, disassemble or rework the shock.

Only a qualified and authorized Scott service staff/shock service center should do this.

To open a shock which is under pressure can be dangerous and may cause injuries!

The Scott Equalizer TC Shock always must be adjusted to the rider's weight to warrant perfect function.

Therefore check before every ride the shock for fitting air pressure.

Riding a defective or not properly working shock can result in the loss of control over the bike and may cause severe or dangerous injuries!

In case you want to disassemble the shock from the bike for service or other reasons please note the recommended tightening torque of 5Nm for the shock bolts.

Scott recommends strongly the use of a torque key to prevent from damages on shock, shock bushings or frame.

In addition the shock bolts should be fixed with Loctite medium (blue) to prevent the bolts from getting unscrewed.

Damages caused by improper assembly or bad maintenance as mentioned above, are not covered by warranty.

Once the recommended check up is made by Scott or a shock service authorized by Scott, it is reported in the maintenance schedule at the end of the manual, which will then enable you to claim for warranty within the warranty period.

The owner of the shock is responsible for the costs of the service.

To ship the shock to Scott or the shock service authorized by Scott please contact your local Scott dealer.



WARRANTY

Model _____

Year _____

Size _____

Frame _____

WARRANTY

SCOTT warrants its Equalizer TC Shock for two years for defects in material and/or workmanship. The warranty period starts at the day of purchase of the completely assembled bike or of the Equalizer TC Shock. This warranty is limited to the first buyer, what means the first person who uses the bike and only with the use it was made for. The bike or the shock is to purchase via authorized SCOTT-dealers to the exclusion of purchases via internet auctions.

It is obligatory to give a copy of the bill of purchase together with the defective shock in case of a warranty claim given that it provides evidence of purchase. Otherwise no warranty is granted.

In case of a warranty claim the decision to repair or to replace the defective shock is up to SCOTT. Non defective parts will only be replaced at the guarantee's own expense.

Following wear and tear shock elements are not covered by the warranty:

- all seals and mud scrapers
- all piston bushings and sliders
- the surface of the piston
- the fixation bushings
- the shock bolts

Following damages are not covered by the warranty:

- improper use
- damages on the piston seals caused by high pressure washers
- damages in the surface of the shock or piston caused by cable housings, stones or crashes

Date of Service:

- any attempts to disassemble the rear shock
- changes in technical specifications
- oil changes not made at SCOTT or Shock Service Centers authorized by SCOTT
- neglecting the service and maintenance periods mentioned in the maintenance schedule of this manual (please refer to the maintenance schedule listed above)

Claims must be made directly through an authorized dealer with the protocol of handing over. For information regarding the nearest dealer, write or call this company or the national SCOTT distributor.

Under reservation of national warrant of merchantability.

Dealers Signature:



SCOTT SERVICE PLAN

Model _____

Service comment : _____

Year _____

Size _____

Frame _____

Date of Service:

Dealers Signature:

SCOTT SERVICE PLAN

Model _____

Service comment : _____

Year _____

Size _____

Frame _____

Date of Service:

Dealers Signature:



SCOTT SERVICE PLAN

Model	_____	Service comment :	
Year	_____		_____
Size	_____		_____
Frame	_____		_____

Date of Service:

Dealers Signature:

SCOTT SERVICE PLAN

Model	_____	Service comment :	
Year	_____		_____
Size	_____		_____
Frame	_____		_____

Date of Service:

Dealers Signature:

ENGLISH

DEUTSCH

FRANÇAIS



SCOTT SERVICE PLAN

Model _____

Service comment : _____

Year _____

Size _____

Frame _____

Date of Service:

Dealers Signature:

SCOTT SERVICE PLAN

Model _____

Service comment : _____

Year _____

Size _____

Frame _____

Date of Service:

Dealers Signature:

