



SCOTT 2010 BIKE OWNERS MANUAL

SAG-BOY

The lengths of the grey beam shows the optimum eye-to-eye distance of the rear shock.

Der graue Balken zeigt den optimalen Bolzenabstand des Dämpfers.

La longueur de la barre grise représente l'écart optimal entre les points de fixation de l'amortisseur

 RANSOM



The Ransom should be adjusted exactly to the current rider for reaching maximum safety and fun while riding. All adjustments should be done at the local Scott dealer or following to this manual.



CONTENT

> Ransom Concept	P. 02
> Geometry/Technical Data Ransom	P. 03
> Shock Technology	P. 04
> Scott Sealed Cable Routing	P. 05
> Adjustment of Seatpost-Height	P. 06
> Set-Up Ransom with Equalizer TC	P. 07
> Use of other Rear Shocks	P. 07
> Replaceable Drop Outs	P. 08/09
> Front Fork Set-Up/Change of Front Fork	P. 10
> Pivot Maintenance	P. 10
> Warranty	P. 10/11



RANSOM CONCEPT

Ransom is the result of 2 years of research and development not only looking for a lightweight but also a durable frame for an innovative suspension technology in combination with an optimized kinematics of the rear swingarm.

The combination of an optimized kinematics with a revolutionary suspension technology closes the gap between dual suspension marathon bikes (e.g. Genius MC) and the new generation of hardcore freeride bikes (e.g. Nitrous 06).

Ransom was designed for riders looking for a "non-bobbing" long travel all mountain bike with a maximum travel of 165mm.

Scott does not see frame, rear shock and kinematics as single components which are assembled together on a bike, but as a concept with all these components working together and offering an outrageous function by matching perfectly.

The Ransom Concept is based on a new designed multi-pivot technology.

In combination with the linear shock characteristics the chain tension will be reduced and doing so the pedaling will not influence function or movement of the rear swingarm.

This system, named TC (Traction Control), combined with the Power Stabilizer and the Intelligent Rebound Valve of our new Equalizer Shock is used on all Ransom models.

The combination of these systems eliminates completely the troublesome bobbing as well as the kick-back of the shock after a big impact or jump.

No power will be lost and an optimum power transfer is guaranteed as the swingarm, in contrary to locked or automatic-locking systems, can follow the trail surface and will offer perfect traction and higher speed.

In addition the rebound is adjusted automatically to the impact force/speed.

GEOMETRY/TECHNICAL DATA RANSOM

Size	Headangle	HT Length	TTHorizon	Seatangle	Top ST	CST Length	BB OS
S	C:68°/A:67°	110	560	73.5°	440	430	+ 16
M	C:68°/A:67°	110	585	73.5°	460	430	+ 16
L	C:68°/A:67°	120	610	73.5°	480	430	+ 16
XL	C:68°/A:67°	130	635	73.5°	510	430	+ 16

C: Carbon Frame

A: Alloy Frame

Travel 165/100/0mm

Suspension Ratio 3.30

Shock (Eye to Eye) 190mm

Hardware Mainframe 22,2mm x 6mm,

Hardware Swingarm 18,0mm x 6mm,

Seatpost diameter 34,9mm

Headset 1 1/8" semi integr. with 44.0mm cups

Fork travel 145mm - 160mm

Fork length 540mm

BB housing 73mm

Front derailleur Topswing 31,8mm Downpull

Chainguard ISCG Standard

Bearings 4 x 61900 (22x10xT6), 4 x 63800, (19x10xT7), 2 x 605 (14x5xT5)



SHOCK-TECHNOLOGY

The heart of the TC-System is the new developed and innovative Scott Equalizer TC Shock, offering five functions which make this system possible.

By using the remote lever you can chose following functions:

1. ALL TRAVEL MODE: full travel of 165mm
2. TRACTION MODE: by reducing the internal chamber volume inside the shock the travel of the shock will be reduced to around 60% (approx. 100mm) the characteristic of the air spring gets harder. This results in climbing without "bobbing" and offers still optimum traction of the rear wheel.
3. LOCK OUT MODE: the shock is locked, climbing on asphalt roads is now possible without any power loss. Simultaneous a blow-off-system prevents the shock being damaged in case the rider did not open the system while crossing obstacles.

You will find the following positions on the remote lever: **[1]**

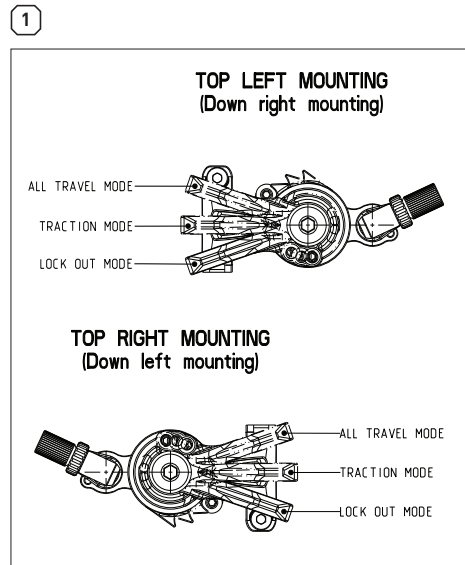

remote lever

In addition following features can be found on the Equalizer TC Shock:

4. POWER STABILIZER: option to ride with or without Pedal Platform by just tapping 1 button on the shock. **[2]**
5. INTELLIGENT REBOUND VALVE: the new developed rebound valve can distinguish between soft and hard impacts and adapts automatically the speed of the rebound based on this to avoid a kick-back of the shock after a hard impact or jump.

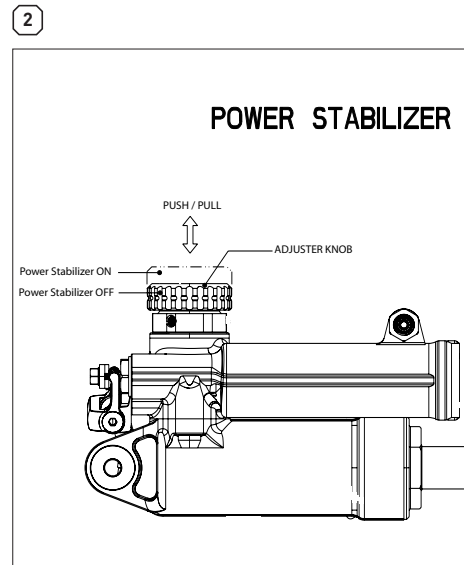

rebound knob/ps knob

SCOTT SEALED CABLE ROUTING

The direct and straight cable system on all our full suspension models allows Smart Cable Routing which is very resistant against water and dirt.

To change the cables simply unscrew and open the cable brackets on the downtube. **[3]**



Smart Cable Routing

MECHANICS HINT

The outer housing of the cables can also be fixed on the bottle cage with cable fixers, the two brackets below the cage are not needed anymore. **[4]**

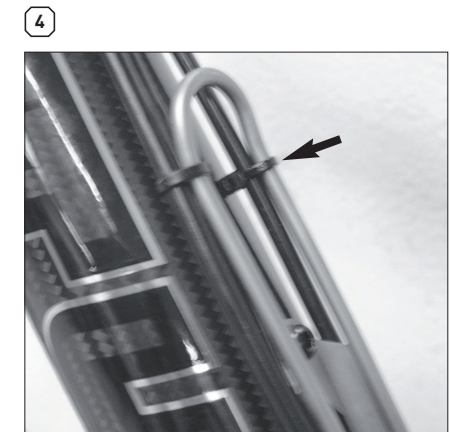

Mechanics hint



ADJUSTMENT OF SEATPOST-HEIGHT

Important:

The seatpost has to be inserted into the seattube at a minimum of 100mm and must not be closer than 25 mm to the rebound adjuster knob. **[5]**

Important!

Note that you have to mount the Equalizer TC Shock **always** with both containers as shown underneath.

Mounting the rear shock in a different position can cause severe damages to the frame, the swingarm and the rear shock. **[6]**

SET-UP RANSOM/ EQUALIZER TC

The Set-Up of the Equalizer TC Shock is shown in the manual "Scott Equalizer Shock 06" attached to this bike and can be done within a few minutes.

In case you want even more detailed figures of air pressure or tuning hints, you can download a program under www.scott-sports.com as a pdf file. **[7]**

Important:

After a dismantlement of the rear shock, both fixing bolts should be tightened with a tightening torque of 5Nm/44in-lbs. If this is not done correctly the rear shock can be damaged.

SET-UP OF OTHER SHOCK MODELS

If you want to use a different rear shock model than the one originally on the bike, please make sure that the shock will not in any position hit the frame and cause a damage to the frame.

Please follow the instruction below:

Please make sure that the rear shock or its accessory parts do not touch the frame when mounting or suspending.

For doing so remove the coil, install the shock and compress the shock completely.

If the shock touches the frame while doing so, do not use this shock in order to avoid damage to frame, swingarm or shock.

5



decal seattower

6

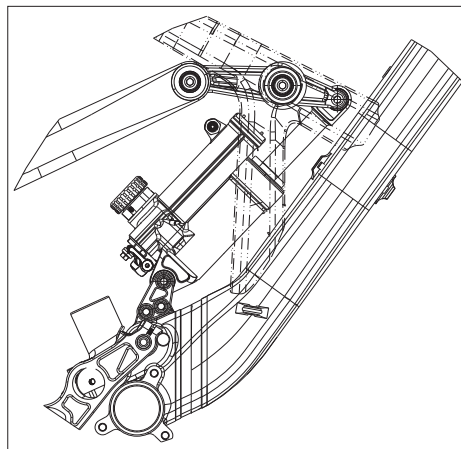

tc equalizer shock in frame

7

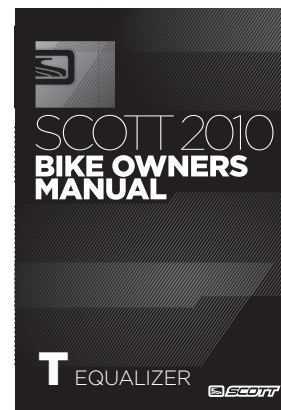

equalizer shock manual



REPLACEABLE DROPOUTS

On Ransom bikes of model year 06 you can use 2 different styles of dropouts

Both drop outs are assembled to the swingarm with 3 bolts and nuts each, tightening torque is 9Nm/79in-lbs. (5mm allen key/insert needed)

1. Drop out for standard QR rear hub

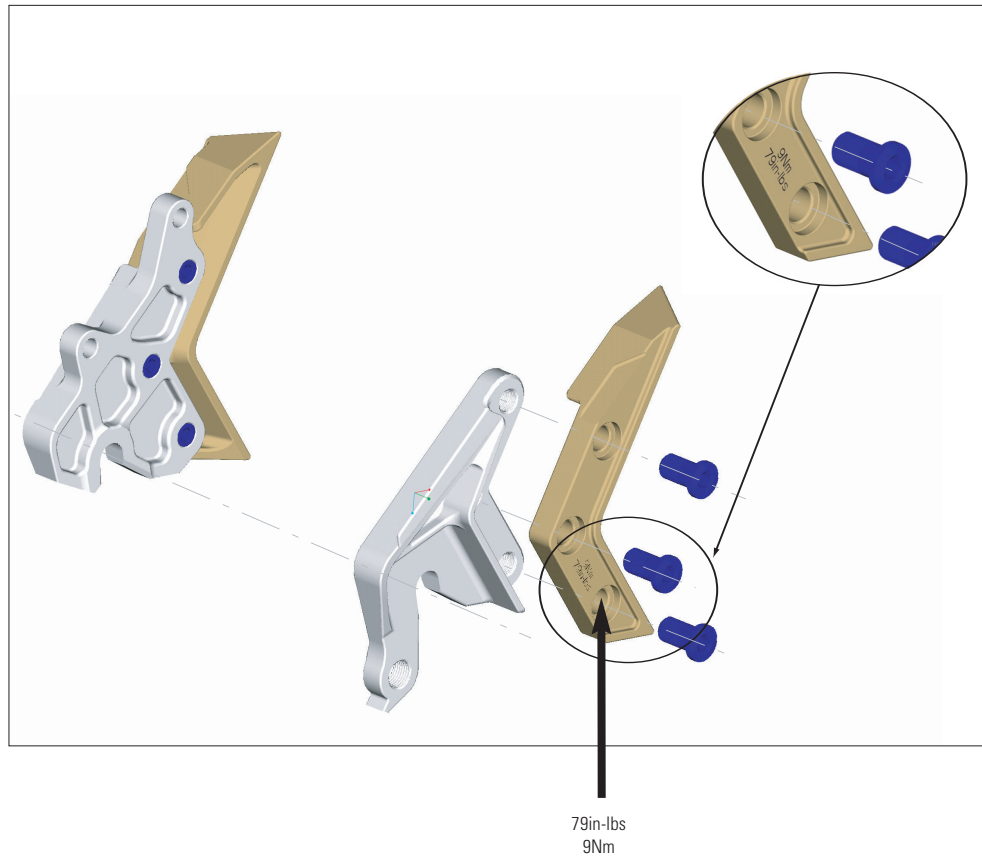

REPLACEABLE DROPOUTS

2. Drop out for 12mm through axle system rear hub:

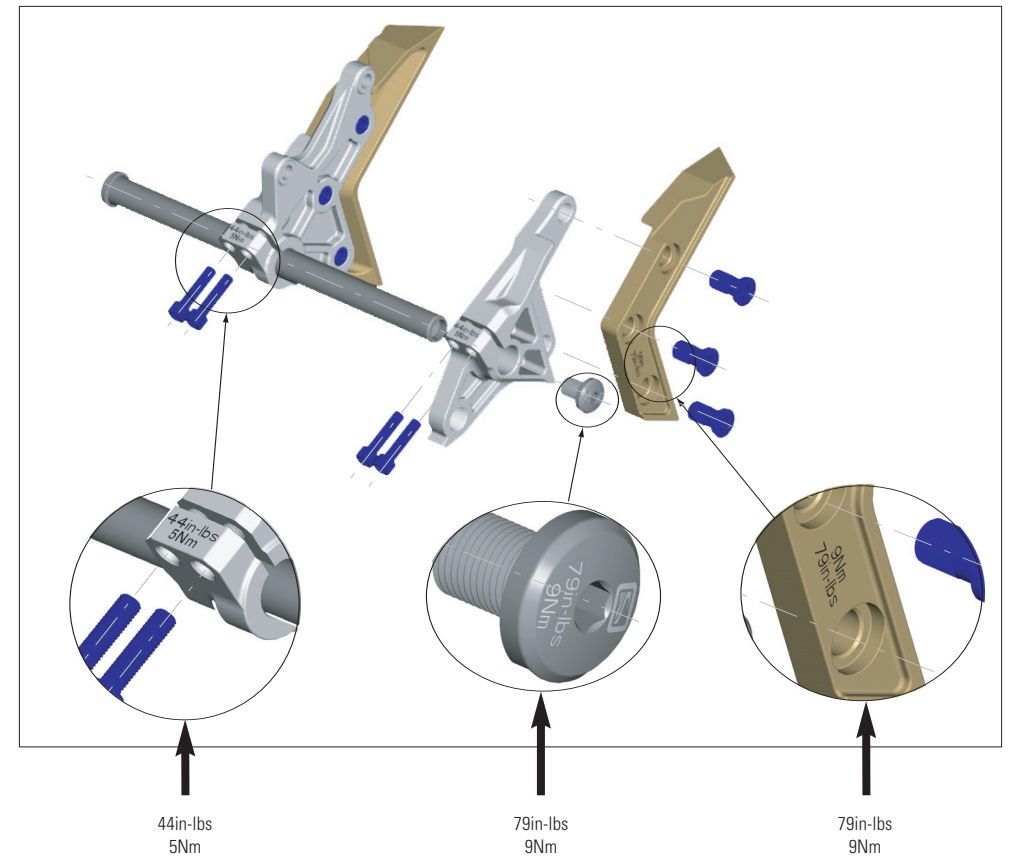

FRONT FORK SET-UP/CHANGE OF FRONT FORK

For the set up of the front fork please use the fork specific manual attached to the bike.

We recommend to use front forks with a travel between 145-160mm, as this will not influence the geometry and alter handling of the bike.

PIVOT MAINTENANCE

The pivot and bearings on SCOTT Ransom are extremely easy to maintain.

An external treatment with a grease spray after every bike wash is all you have to do. We do not recommend heavy grease sprays since these will leave a film on the parts which is difficult to remove. We recommend the same for the chain also.

If you have to change the bearings you can order them included in a service kit at your local SCOTT dealer or buy them with international parts number as shown above in the specs list in a hardware store.

In case of a change of the bearings or of the rear swingarm you should contact your local SCOTT dealer as you need special tools for disassembly and assembly.



WARRANTY

Model _____

Year _____

Size _____

Frame _____

SCOTT bikes are made using the most innovative production and quality methods. They are equipped with best components of well known parts suppliers.

Doing so SCOTT warrants its frames and swingarms for five years (subject to compliance with maintenance ranges, see below) and SCOTT forks (provided it is a fork of SCOTT) for two years for defects in material and/or workmanship in case of purchase of completely assembled bikes.

This warranty of 5 years for the frames shall only be granted in case once a year a maintenance service has been effected according to maintenance requirements as set forth in this manual by an authorised SCOTT dealer.

The authorised SCOTT dealer shall confirm the effected annual maintenance service by stamp and signature.

In case such an annual maintenance service has not been effected the warranty of 5 years for the frame shall be reduced to 3 years.

Costs for maintenance and service have to be born by the owner of the SCOTT bike.

On Gambler the warranty period is limited to 2 years.

The warranty period starts at the day of purchase.

This warranty is limited to the first buyer, what means the first person who uses the bike and only with the use it was made for. Furthermore, this warranty is limited to purchases via authorized SCOTT-dealers to the exclusion of purchases via internet auctions.

In case of a warranty claim the decision to repair or to replace the defective part is up to SCOTT. Non defective parts will only be replaced at the guarantee's own expense.

Fair wear and tear is not covered by the warranty. A complete list of all parts of wear and tear can be found in the next chapter of this manual.

In addition, you will find at the end of this manual a protocol for the handing over of the bike which will remain in copy at the SCOTT dealer after acceptance and signature of the consumer.

It is obligatory to show this protocol of handing over together with the defective part in case of a warranty claim given that it provides evidence of purchase. Otherwise no warranty is granted.

In principle, this warranty is granted worldwide. Claims must be made through an authorized dealer, for information regarding the nearest dealer, write or call this company or the national SCOTT distributor.

Normal wear, accident, neglect, abuse, improper assembly, improper maintenance by other than an authorized dealer or use of parts or devices not consistent with the use originally intended for the bicycle as sold are not covered by this warranty.

Hereby SCOTT grants a voluntarily manufacturer's warranty. Additional entitlements according to national warrant of merchantability are reserved.

