



**SCOTT 2011
BIKE OWNERS
MANUAL**

SCOTT SPORTS SA | 17 RTE DU CROCHET | 1762 GIVISIEZ | SWITZERLAND
© 2009 SCOTT SPORTS SA, ALL RIGHTS RESERVED | SCOTT-SPORTS.COM



GAMBLER





The Gambler should be adjusted exactly to the current rider for reaching maximum safety and fun while riding. All adjustments should be done at the local Scott dealer or following to this manual.

CONTENT

Gambler Concept	P. 004
Geometry/Technical Data Gambler	P. 005
Adjustment of head angle	P. 007
2 different headtube inserts	P. 008
3 different rear travel options	P. 009
Recommended Tools for the Shock Set-Up	P. 009
Basic Set-Up of the Gambler Rear Suspension	P. 010
Adjustment of Seatpost-Height	P. 012
IDS Drop Out System	P. 013
Front Fork Set-Up/Change of Front Fork	P. 014
Pivot Maintenance	P. 014
Warranty	P. 016



GAMBLER CONCEPT

Gambler is the result of 2 years of research and development searching for one of the most versatile and durable FR and DH bikes available on the market, but still easy in set-up and maintenance.

Scott's focus was to combine solid construction with optimized kinematics. This respecting the demands of riders concerning geometry, suspension characteristics, low center of gravity and stiffness.

Gambler was designed for riders looking for a dual suspended FR bike or a race oriented DH bike offering rear wheel travel between 190 and 230 mm.

Scott does not see frame, rear shock and kinematics as single components which are assembled together on a bike, but as a concept with all these components working together and offering an outrageous function by matching perfectly.

The Gambler Concept is based on a new designed multi-pivot technology.

In combination with the linear coil-over shock characteristics the kinematics guarantees a progressive suspension, adapted to smooth riding (beginning of travel) as well as extreme jumps (end of travel).

GEOMETRY DATA GAMBLER

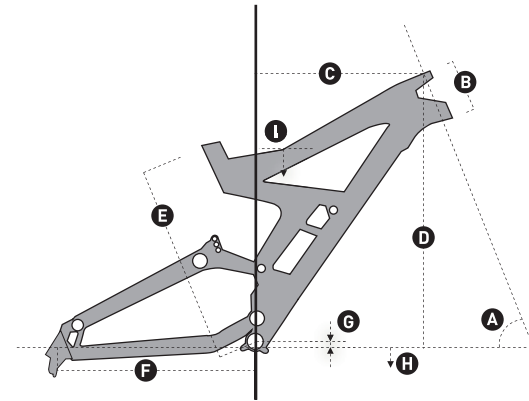

	A	B	C		D		E	F		G		H		I		J	K
Size	Head angle	Head tube length	Reach	Stack	BB center to top of seat tube	Chainstay length	BB offset	BB height	Standover height	Wheel base	Stem length						
	°	mm inches	mm inches	mm inches	mm inches	mm inches	mm inches	mm inches	mm inches	mm inches	mm						

GAMBLER FR

short	66.0°	115 4.5	375 14.7	586 23.1	424 16.7	430 16.9	25 1.0	370 14.6	790 31.1	1135 44.7	40					
long	66.0°	115 4.5	410 16.5	586 23.1	424 16.7	430 16.9	25 1.0	370 14.6	790 31.1	1170 46.1	40					

GAMBLER DH

short	64.0°	115 4.5	375 14.7	586 23.1	424 16.7	440 17.3	25 1.0	370 14.6	790 31.1	1135 44.7	50					
long	64.0°	115 4.5	410 16.5	586 23.1	424 16.7	440 17.3	25 1.0	370 14.6	790 31.1	1170 46.1	50					



TECHNICAL DATA GAMBLER

Travel	190 / 210 / 230mm
Suspension Ratio	2.5 / 2.75 / 3.0
Piston stroke	76mm
Shock length (Eye to Eye)	241mm
Hardware Mainframe	22,2mm x 8mm
Hardware Swingarm	40mm x 8mm
Seatpost diameter	34,9mm
Headset	1 1/8" or 1.5", depending on headtube insert
Fork travel	180 - 200mm
Fork length	568mm
BB housing	83mm
Chainguide system	ISCG / ISCG05 tab
Rear Hub Width	150mm
Bearings	2 x 61901 (24 x 12 x T6) 6 x 61902 (28 x 15 x T7)

ADJUSTMENT OF HEAD ANGLE

On Gambler you can adjust the headangle within a few minutes for a better handling depending on your riding style and track condition/style.

How to adjust the headangle:

You need

- a 4mm Allen key bit for a tightening torque key
- a 56mm wrench (attached to this bike)

1. Loose the three screws on the head of the headtube with a 4mm allen key but do not remove them completely. These screws hold the insert in Place. Please note that it is not necessary to disassemble the fork or any other components.
2. Turn the insert with the 56mm wrench which is attached to your bike/frameset. The slot of the insert should always be in line with the slot of the headtube clamp. The resulting angle is engraved in the insert for both options.

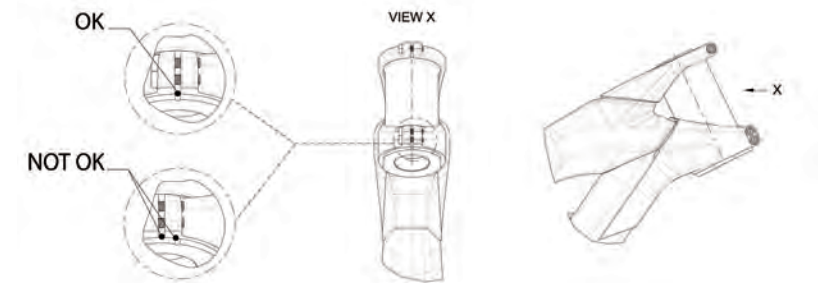

3. IMPORTANT:
Please make sure that there is no gap between the collar on the downside of the insert and the head tube clamp on the frame.

4. tighten the 3 screws with 5Nm/44in-lbs

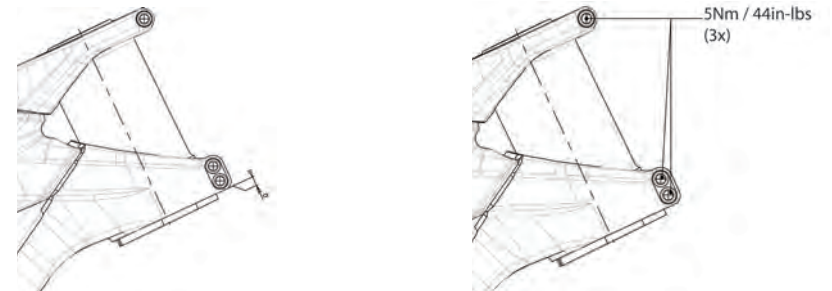

2 DIFFERENT HEADTUBE INSERTS

On Gambler you have 2 options for the headset diameter (1 1/8" and 1.5"). You can order the headtube inserts via your local Scott dealer with:

210127	Headtube Insert Gambler	1 1/8"	1size
210128	Headtube Insert Gambler	1.5"	1size

For removing/assembling them please contact your local Scott dealer as you might need some special tools for the headset dis-/assembly as well as a tightening torque key to fix the inserts in the headtube section.

Important:
It is very important to follow the tightening torque indications shown on the parts.

3 DIFFERENT REAR TRAVEL OPTIONS

On Gambler you have 3 options for the rear travel as shown on the drawing below:

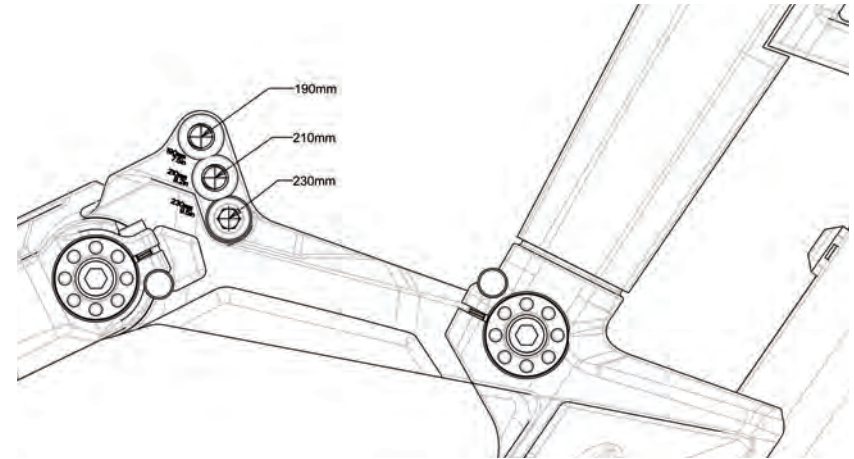

RECOMMENDED TOOLS FOR THE SET-UP

Please read this manual and the manual of the rear shock manufacturer carefully before you start the set-up procedure.

In addition we strongly recommend using a tightening torque key with a 6mm allen key insert.



SET-UP GAMBLER

The Set-Up of the rear shock can be easy done within a few minutes.

Please take this time to avoid dangerous riding performance and to get the best out of your Gambler.

Please make sure that the coil spring on the shock matches to your riding weight (including your riding gear).

We recommend following coil springs:

Weight (kg)	190 mm rear travel	210 mm rear travel	230 mm rear travel
50 - 60	250 x 3.25	300 x 3.25	350 x 3.25
60 - 70	300 x 3.25	350 x 3.25	400 x 3.25
70 - 80	350 x 3.25	400 x 3.25	450 x 3.25
80 - 90	400 x 3.25	450 x 3.25	500 x 3.25

For fine tuning the SAG and the corresponding eye-to-eye distance of the shock bolts you can tighten or release the pretension of the coil spring but please respect the maximum and minimum spring indications of the shock manufacturer.

The eye-to-eye distance between the shock bolts should be in basic set up 212mm (40% SAG).

For further details on the shock set-up please follow the indications of the rear shock manufacturer attached to this bike.

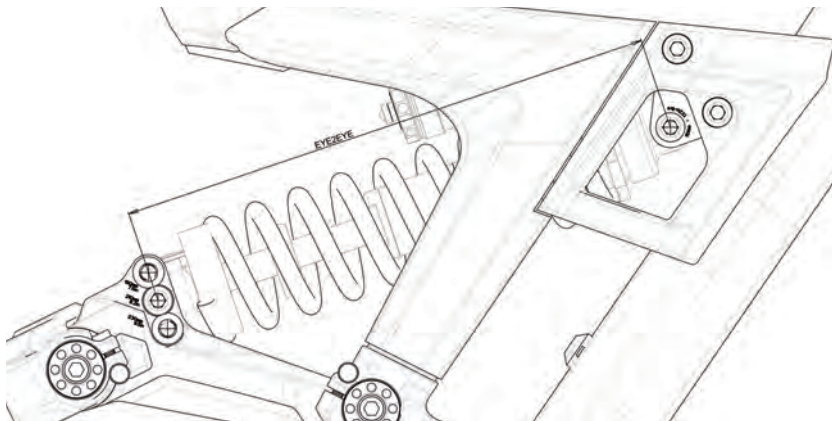

BASIC SET-UP OF REBOUND

“Rebound” describes the speed the shock comes back to its original length after absorbing an obstacle.

By using the red rebound screw you can adjust the rebound step by step.

Please refer to the following instruction:

Ride your bike off a pavement (remain in the saddle) and check how many times it bounces.

- if it bounces 1-2 times, the set up is good.
- If it bounces more than 3 times the rebound is too fast.
Turn the screw 1-2 “clicks” clockwise
- If it does not bounce the rebound is too slow.
Turn the screw 1-2 “clicks” counter clockwise.

IMPORTANT

After a dismantlement of the rear shock, both fixing bolts should be tightened with a tightening torque of 35Nm/308in-lbs.

If this is not done correctly the rear shock can be damaged.

IMPORTANT

Note that you have to mount the rear shock always as shown underneath.

Mounting the rear shock in a different position can cause severe damages to the frame, the linkage levers and the rear shock.

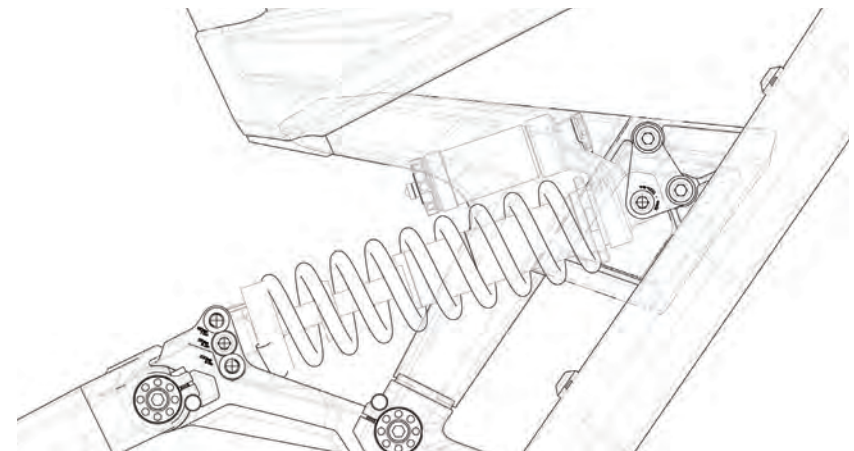



SET-UP OF OTHER SHOCK MODELS

Scott strongly recommends using only the originally specified shock with the Gambler bike, as we have chosen carefully both parts for a perfect matching combination.

If you want to use a different rear shock model than the one originally on the bike, please make sure that the shock will not in any position hit the frame and cause a damage to the frame.

Please follow the instruction below:

Please make sure that the rear shock or its accessory parts do not touch the frame when mounting or suspending.

For doing so release the air/remove the coil, install the shock and compress the shock completely.

If the shock touches the frame while doing so, do not use this shock in order to avoid damage to frame, swingarm or shock

ADJUSTMENT OF SEATPOST-HEIGHT

IMPORTANT:

The seatpost has to be inserted into the seattube at a minimum of 80mm.

Never use another seatpost diameter than 34.9mm or try to use a shim/reducer between seatpost and frame.

When lowering down the seatpost, please make sure that it will not hit the shock below while riding! This could result in serious damage on bike parts and result in a dangerous riding condition.

IDS DROP OUT SYSTEM

The Gambler offers the possibility not only to change drop out hanger in case of damage, you also can choose between different 3 different drop outs of the Scott IDS (Interchangeable Drop-Out System):

Inline you will find on Gambler FR following drop out:



Inline on Gambler DH you will find following drop out (10mm longer as FR drop out):

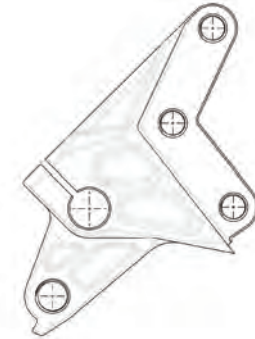

Another Option is SRAM-Maxle System for 12mm/150mm through axle hubs (same length as your FR dropout), available at your local authorized Scott dealer:

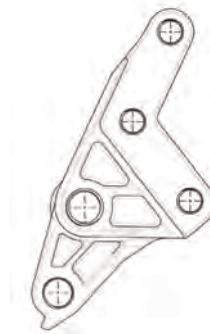



FRONT FORK SET-UP/ CHANGE OF FRONT FORK

For the set up of the front fork please use the fork specific manual attached to the bike. We recommend using front forks with a travel between 180 and 200 mm (568mm fork length), as this will not influence the geometry and alter handling of the bike.

PIVOT MAINTENANCE

The pivots and bearings on SCOTT Gambler are extremely easy to maintain. An external treatment with a grease spray after every bike wash is all you have to do. We do not recommend heavy grease sprays since these will leave a film on the parts which is difficult to remove. We recommend the same for the chain also. If you have to change the bearings you can order them included in a service kit (Scott article number: 210126) at your local SCOTT dealer or buy them with international parts number as shown above in the specs list in a hardware store.

In case of a change of the bearings or of the rear swingarm you should contact your local SCOTT dealer as you need a special tool kit for disassembly and assembly.

NOTES

.....

.....

.....

.....

.....

.....

.....

.....

.....

.....

.....

.....

.....

.....

.....

.....

.....

.....

.....

.....

.....



WARRANTY

Model

Year

Size

Frame

Date of purchase



WARRANTY

SCOTT bikes are made using the most innovative production and quality methods. They are equipped with best components of well known parts suppliers.

Doing so SCOTT warrants its frames and swingarms for five years (subject to compliance with maintenance ranges, see below) and SCOTT forks (provided it is a fork of SCOTT) for two years for defects in material and/or workmanship in case of purchase of completely assembled bikes.

This warranty of 5 years for the frames shall only be granted in case once a year a maintenance service has been effected according to maintenance requirements as set forth in this manual by an authorised SCOTT dealer.

The authorised SCOTT dealer shall confirm the effected annual maintenance service by stamp and signature.

In case such an annual maintenance service has not been effected the warranty of 5 years for the frame shall be reduced to 3 years.

Costs for maintenance and service have to be born by the owner of the SCOTT bike.

On Gambler, Voltage Fr and Volt-X the warranty period is limited to 2 years.

The warranty period starts at the day of purchase. This warranty is limited to the first buyer, what means the first person who uses the bike and only with the use it was made for. Furthermore, this warranty is limited to purchases via authorized SCOTT-dealers

The warranty is solely granted in case of purchase of a completely assembled bike to the explicit exclusion of purchases of not completely assembled bikes.

In case of a warranty claim the decision to repair or to replace the defective part is up to SCOTT. Non defective parts will only be replaced at the guarantee's own expense.

Fair wear and tear is not covered by the warranty.

A complete list of all parts of wear and tear can be found in the next chapter of this manual.

In addition, you will find at the end of this manual a protocol for the handing over of the bike which will remain in copy at the SCOTT dealer after acceptance and signature of the consumer.

It is obligatory to show this protocol of handing over together with the defective part in case of a warranty claim given that it provides evidence of purchase. Otherwise no warranty is granted.

In principle, this warranty is granted worldwide. Claims must be made through an authorized dealer, for information regarding the nearest dealer, write or call this company or the national SCOTT distributor.

Normal wear, accident, neglect, abuse, improper assembly, improper maintenance by other than an authorized dealer or use of parts or devices not consistent with the use originally intended for the bicycle as sold are not covered by this warranty.

Hereby SCOTT grants a voluntarily manufacturer's warranty. Additional entitlements according to national warrant of merchantability are reserved.

