



**SCOTT 2011  
BIKE OWNERS  
MANUAL**

SCOTT SPORTS SA | 17 RTE DU CROCHET | 1762 GIVISIEZ | SWITZERLAND  
© 2009 SCOTT SPORTS SA, ALL RIGHTS RESERVED | SCOTT-SPORTS.COM



**GENIUS**





The Genius should be adjusted exactly to the current rider for reaching maximum safety and fun while riding. All adjustments should be done at the local Scott dealer or according to this manual.

## CONTENT

Genius Concept .....	P. 004
Geometry Genius .....	P. 005
Technical Data Genius .....	P. 006
TWINLOC Remote Control Lever .....	P. 007
Equalizer 2 Shock and TWINLOC Remote Control Lever .....	P. 014
Basic Set-Up of the TWINLOC Remote Control .....	P. 015
Recommended Tools for the Shock Set-Up .....	P. 019
Set-Up Genius with Equalizer 2 Shock .....	P. 020
Set-Up of Rebound Equalizer 2 Shock .....	P. 022
Set-Up of other Shock Models .....	P. 025
Scott Smart Cable Routing .....	P. 025
Cable housing length .....	P. 026
Adjustment of Seatpost Height .....	P. 026
Replaceable Drop Out .....	P. 027
Front Derailleur Fixation .....	P. 027
Front Fork Set-Up/ Change of Front Fork .....	P. 028
Pivot Maintenance .....	P. 028
Warranty .....	P. 030



# GENIUS CONCEPT

Genius is the result of 2 years of research and development for the lightest mountain bike frame set available on the market to be used for marathon, trail and long distance riding, hitting the scale at below 2250 grams including the frame, Scott/DT Equalizer 2 shock.

Scott's focus was not only on lightweight but also on a durable frame with an innovative suspension technology in combination with an optimized kinematics of the rear swingarm.

The combination of an optimized kinematics with an extraordinary suspension technology closes the gap between superlight dual-suspension bikes (e.g. Scott Spark) and the new generation of all mountain bikes (e.g. Scott Ransom).

Genius was designed for riders looking for a dual suspended marathon and tour/long distance bike offering a maximum rear wheel travel of 150mm.

Scott does not see frame, rear shock and kinematics as single components which are assembled together on a bike, but as a concept with all these components working together and offering an outrageous function by matching perfectly.

The Scott system, named TC (Traction Control) will allow you to reduce by remote control the rear wheel travel from 150mm to 95mm including a more progressive spring rate but still offering a supple break away.

No power will be lost and an optimum power transfer is guaranteed as the swingarm, in contrary to locked or automatic-locking systems, can follow the trail surface and will offer perfect traction and higher speed while standing on the pedals.

# GEOMETRY GENIUS

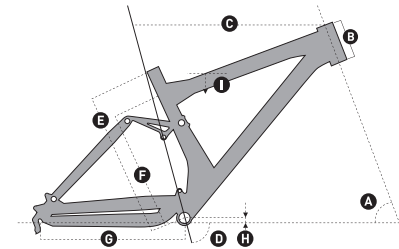

	A	B	C		D	E		F		G		H		I				
Size	Head angle	Head tube length		Effective top tube horizontal		Seat angle	BB center to top of seat tube		BB center to top tube center		Chainstay length		BB offset		Standover height		Stem length	Crank-arm length
	°	mm inches		mm inches		°	mm inches		mm inches		mm inches		mm inches		mm inches		mm	mm

GENIUS CARBON																		
S	68.3°	100	3.9	555	21.9	73.5°	440	17.3	337	13.3	428	16.9	10	0.4	771	30.4	80	170
M	68.5°	115	4.5	585	23.0	73.5°	450	17.7	358	14.1	428	16.9	10	0.4	786	30.9	80	175
L	68.7°	135	5.3	610	24.0	73.5°	475	18.7	384	15.1	428	16.9	10	0.4	807	31.8	90	175
XL	68.9°	160	6.3	640	25.2	73.5°	500	19.7	410	16.1	428	16.9	10	0.4	830	32.7	100	175

GENIUS ALLOY																		
S	68.5°	110	4.3	555	21.9	73.5°	440	17.3	336	13.2	428	16.9	10	0.4	778	30.6	80	170
M	68.5°	120	4.7	585	23.0	73.5°	450	17.7	358	14.1	428	16.9	10	0.4	791	31.1	80	175
L	68.5°	135	5.3	610	24.0	73.5°	475	18.7	384	15.1	428	16.9	10	0.4	810	31.9	90	175
XL	68.5°	160	6.3	640	25.2	73.5°	500	19.7	410	16.1	428	16.9	10	0.4	833	32.8	100	175

## TECHNICAL DATA GENIUS

Travel	150/95/0mm
Suspension Ratio	3.0
Piston stroke	50mm
Shock length (Eye to Eye)	165mm
Hardware Mainframe	14mm x 6mm
Hardware Swingarm	14mm x 6mm
Seatpost diameter	34,9mm
Headset	1 1/8" semi integr. with 44.0mm cups
Fork travel	140 - 150mm
Fork length	518 - 525mm
BB housing	73mm
Front derailleur	E-type, direct mount, down pull
Bearings	61900-2RS (Ø22xØ10x6) / 61800-2RS (Ø19xØ10x5)

## TWINLOC – REMOTE CONTROL LEVER

The TWINLOC remote control lever is the evolution of the already outstanding TRACLOC system of Scott.

While TRACLOC allows the change on the Scott rear shocks Nude TC and Equalizer 2 between the Scott patented Lock-out, traction and full-mode on the fly from the handlebar, the TWINLOC now allows also the remote control of the front fork to shift between lock-out and open mode at the same time when you change the modes on the Scott rear shox.

The 3 modes on the lever and suspension units are:

- **Full Travel Mode:** full travel rear, full travel front
- **Traction Mode:** traction mode rear, full travel front
- **Lock-out Mode:** lock-out rear, lock-out front

Scott offers different TWINLOC levers with following fork/rear shock combinations:

- **Equalizer 2** with adapters for SRAM /RockShox fork and FOX fork/DT Swiss fork ( Scott Article number: 216350)

Important: You can only assemble the TWINLOC remote lever in "left side upward position" on the handlebar.

You have 3 positions on the TWINLOC remote lever.

- **most forward position:** lock-out rear, lock-out front
- **middle position:** traction mode rear, full travel front
- **most backward position:** full travel rear, full travel front

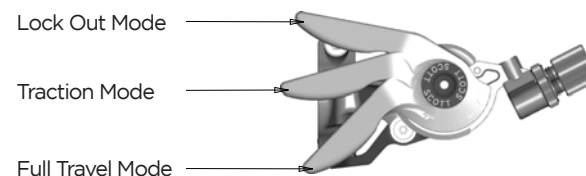





Change the modes by pushing the lever with your fingers frontward and release them by tapping the release button (one mode per push/release)

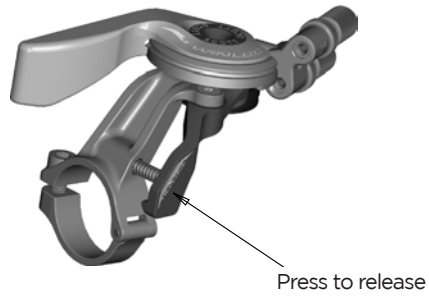

For the different parts of the TWINLOC lever mentioned in the following instruction please refer to the drawing with parts names below:

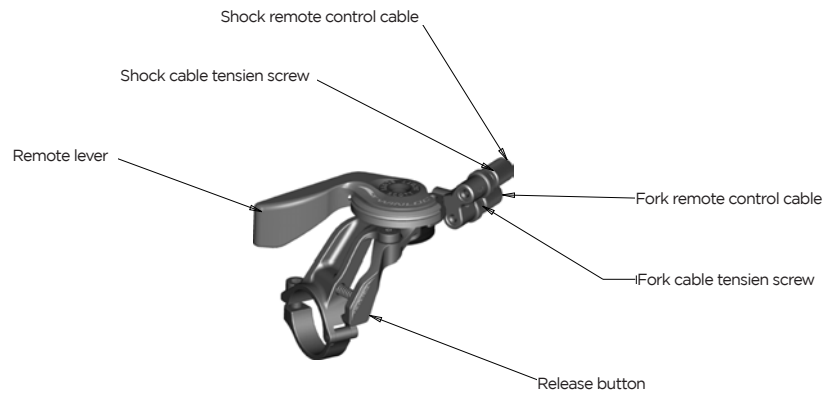

Please note that the cable for the rear shock is ALWAYS the upper cable on the lever as shown in drawing below.



For the assembly of the remote control of the front fork lock-out 2 different cable systems are existing.

The different roll for the pull of the fork remote cable can be changed within few minutes to adapt the lever to your fork model/brand.

You will see on the downside of the roll the indication of fork brand.

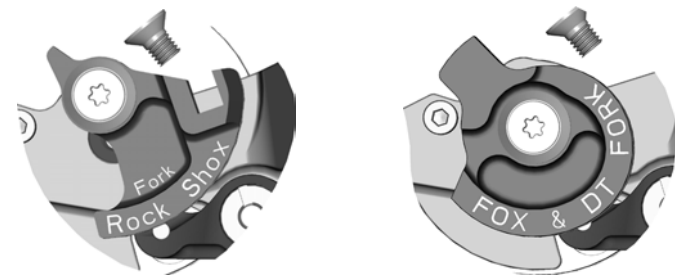



To change the rolls to match another fork brand pls follow the drawings below:

### Roll fork unmounting

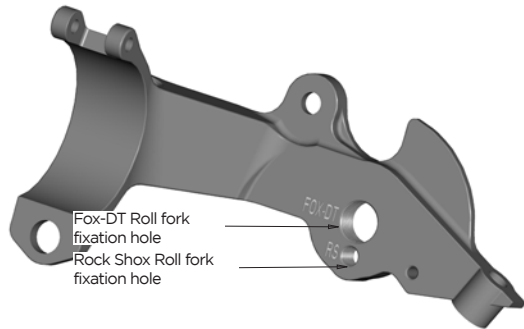
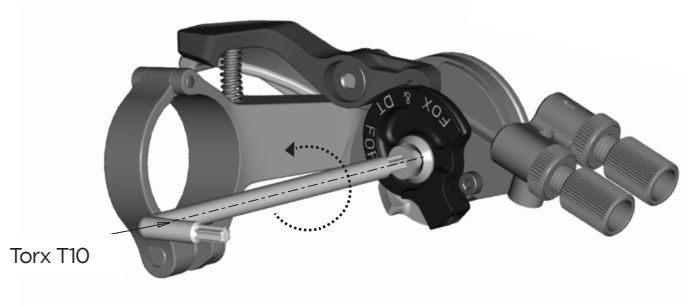

### Roll fork mounting

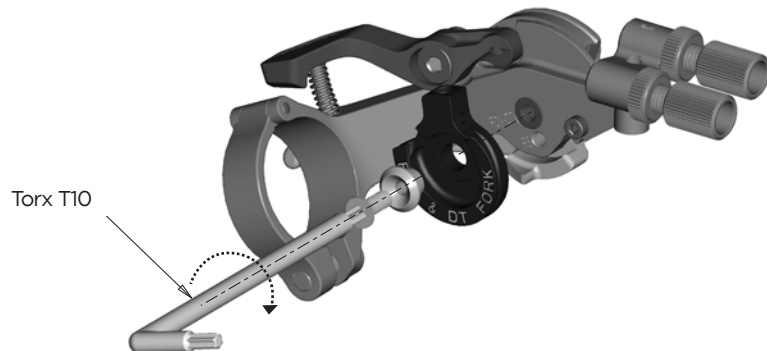

## ASSEMBLY OF THE REMOTE CABLE

### SRAM/RockShox forks:

#### Important:

Please make sure the lockout of SRAM/RockShox fork is activated after transport correctly. Therefore please compress fork 5-10 times before following the manual on remote cable installation and adjustment.

The lever should show on the downside of the cable roll follow indication:

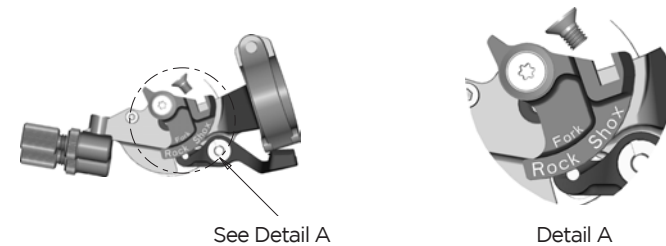

To assemble the cable please bring the lever into the All Travel Mode, push the cable into the lever-eyelet as shown on drawing below, push it through the pre-cut cable housing and fix it at the assembly unit on top of the right side of the fork crown.

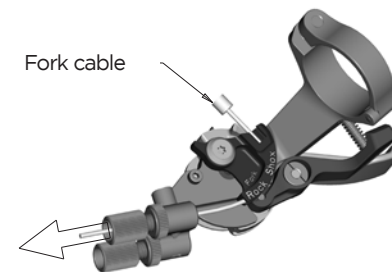

Fix the cable with the 2mm allen screw on the barrel adjuster on the fork crown with a tightening torque of 0.9Nm/ 8lb/in, cut the cable and secure it with a cable end-cap. Please refer for this action also to the manual of SRAM/RockShox attached to the bike.

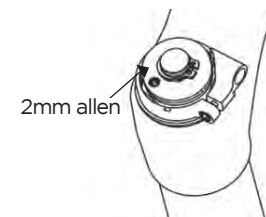

## FOX-DT Swiss forks

### Important:

Please make sure the lockout of FOX/DT fork is activated after transport correctly. Therefore please compress fork 5-10 times before following the manual on remote cable installation and adjustment.

The lever should show on the downside of the cable roll follow indication:

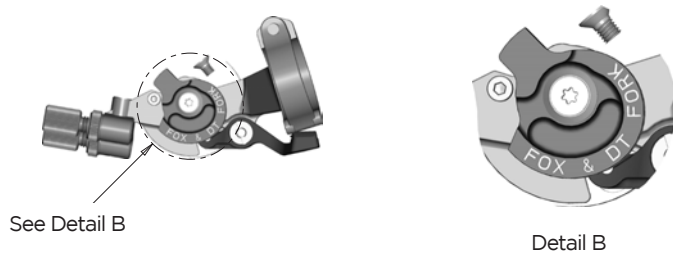

To assemble the cable please bring the lever into the Full (Travel) Mode

Full mode

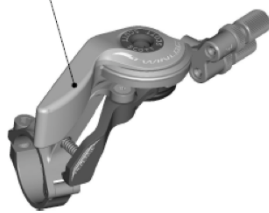

push the pre-cut cable through the pre-cut cable housing into the lever as shown on drawing below

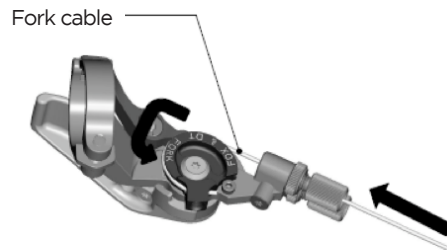

and secure the cable by fixing the 2mm allen screw with a tightening torque of 0.9Nm/ 8lb/in as shown on the drawing below on the roll.

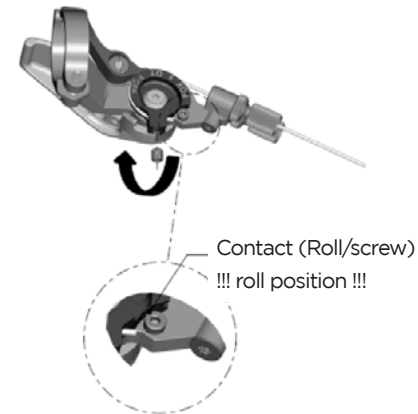

Cut the cable 5mm behind the roll and secure it with a cable end-cap.

Please refer for this action also to the manual of FOX or DT Swiss attached to the bike. In case you need to remove the remote cable completely from the forks of FOX or DT Swiss please follow the instructions of the related fork manuals of the fork manufacturers or contact a fork service center / your local dealer to do so.

### TIP:

To check for accurate cable tension, please try to move the plastic end cap of the cable housing at the barrel adjuster on the remote lever. There should be "no-play" between cap and barrel adjuster.

In case of "play" please turn the barrel adjuster clockwise until "no-play".

## EQUALIZER 2 SHOCK AND TWINLOC REMOTE CONTROL LEVER

In the drawing of the shock and remote lever, shown below, you will see the parts indicated with numbers which will be used in the manual for the adjustment and set-up.

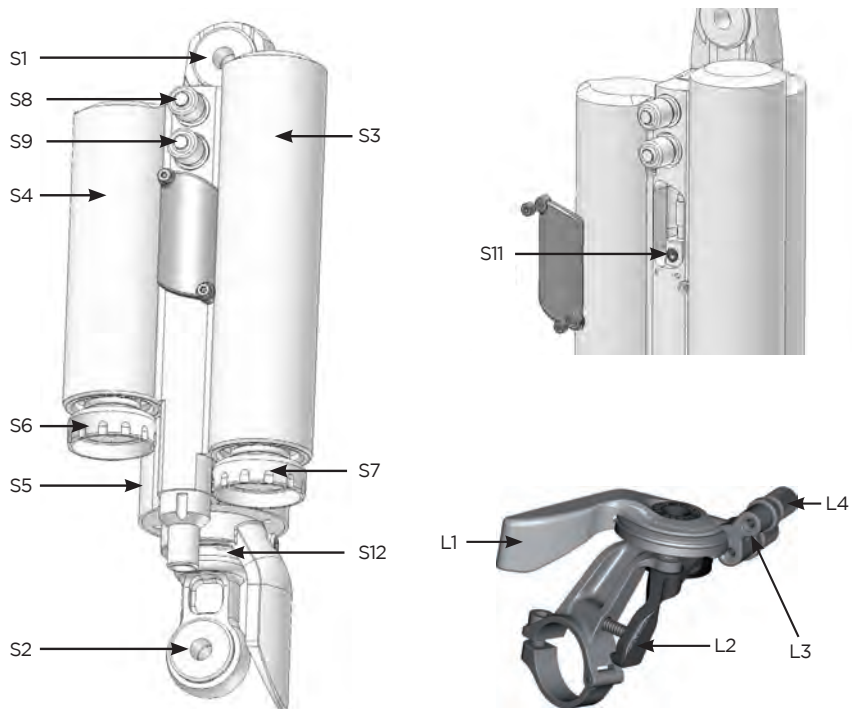

S1 Top eyelet/ Shock Bolt	L1 Remote Lever
S2 Down eyelet/ Shock Bolt	L2 Release Button
S3 Traction Mode Chamber	L3 Remote Control Cable
S4 Full Mode Chamber	L4 Cable Tension Screw
S5 Shock Housing	
S6 Rebound- Screw	
S7 Rebound- Screw	
S8 Positive Chamber Valve	
S9 Negative Chamber Valve	
S10 Remote Control Cable	
S11 Cable fixing Screw (hidden behind dust protector plate)	
S12 Shock Piston	

## BASIC SET-UP OF THE TWINLOC REMOTE CONTROL OF EQUALIZER 2 SHOCK

To ensure perfect function of the Equalizer 2 shock it is very important to follow the steps shown below exactly.

Please note that the following explanation shows a complete exchange/replacement of the cable, so in case you just want to double check e.g. the cable tension please see only steps 1, 7, 8 and 9.

### Important:

For all following actions the TWINLOC lever needs to be in "ALL TRAVEL-MODE" position!

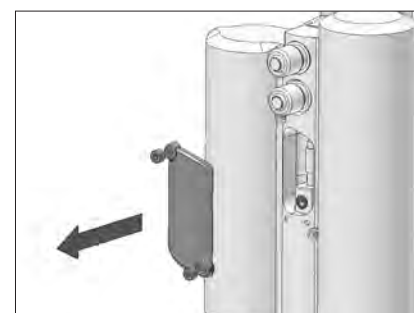

- 1 Remove the cap of the cable housing window on the shock by turning the screws counter clockwise using a 1.5 mm allen key



- 2 remove the end cap of the cable with pliers



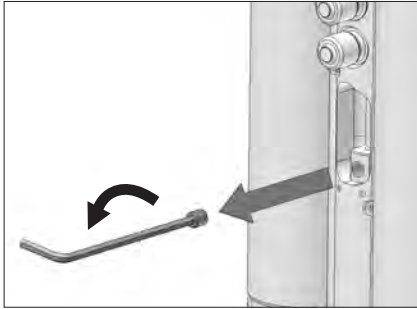

- 3** loosen the cable fixing screw (S10) by turning it counter-clockwise with a 2.0 mm allen key

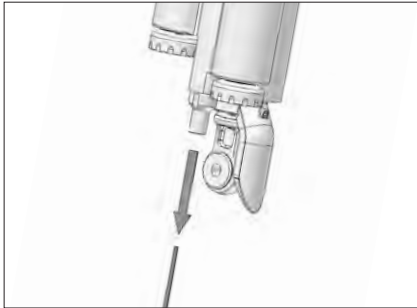

- 4** remove the old cable by pushing/pulling it out from the TWINLOC lever

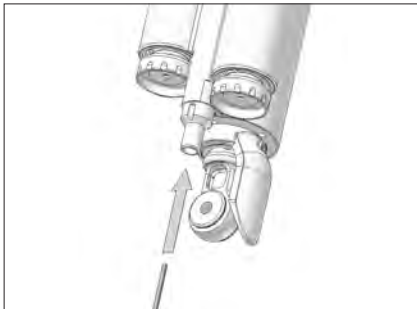

- 5** insert a new cable via lever hole and cable housing and push it into the shock as shown

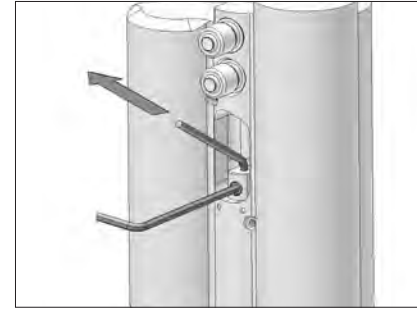

- 6** tighten the cable and fix the cable fixing screw (S10) by turning it clockwise with a 2.0 mm allen key and a max. tightening torque of 1.6 Nm

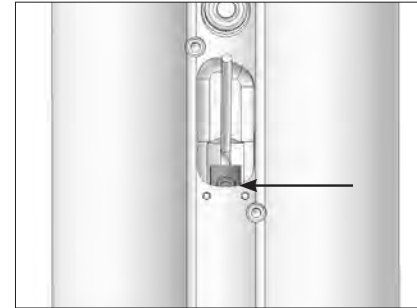

- 7** to double check accurate cable tension please push the TWINLOC lever to "TRACTION-MODE". The mid of the cable fixing screw (S10) should be at the edge of the lower cable housing window on the shock. For fine-tuning please adjust the cable tension via the barrel adjuster (L4) on the TWINLOC lever.

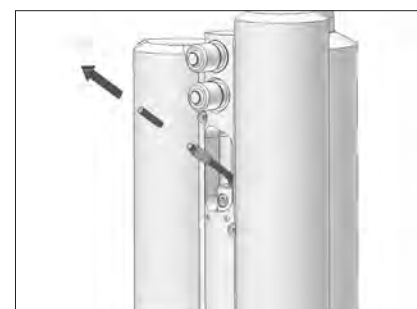

- 8** push the "open-ended" cable cap on the cable until it touches the cable sled, fix it by squeezing it with pliers and cut the cable just above the cap

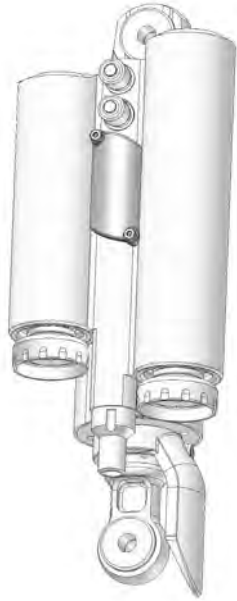

- 9 remount the cap of the cable housing window on the shock by turning them clockwise using a 1.5 mm allen key and a maximum tightening torque of **0.3 Nm**

#### Important:

Please note that the maximum pressure of the Equalizer 2 shock is 28.0bars/406psi in the positive chamber and 22.4bars/325psi in the negative chamber and which means a maximum weight of the rider of 110kg/243lbs incl. riding gear and load.

## RECOMMENDED TOOLS FOR THE SHOCK SET-UP

For the set-up of the shock we recommend to use a shock pump with a scale up to 40 bars/600 psi with a special air valve connector preventing from air getting away while removing the pump from the shock valve, this will result in an exact air pressure.

**Please note that air will flow into the hose and indicator when counterchecking the air pressure, so you have to set up again the recommended pressure after this action.**

**Make sure to balance at least this air loss when you make a check of the air pressure of the shock. Pls also note that the indicators of shock pumps have a tolerance of max. 10%**

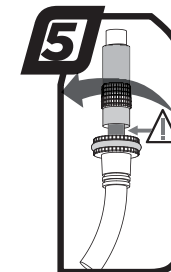
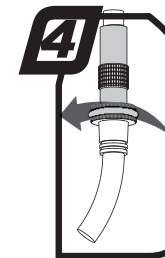
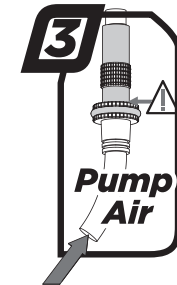
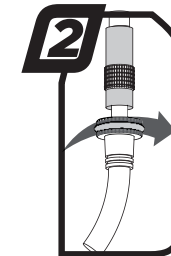
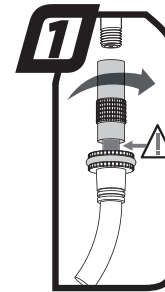

## SET-UP GENIUS WITH EQUALIZER 2 SHOCK

The Set-Up of the Scott/DT Equalizer 2 Shock can be easy done within a few minutes.. To adjust the air pressure of the air chamber of the Scott Equalizer 2 Shock please refer to the following instruction:

1. remove the valve cap of the positive valve (S8) which is the UPPER valve on the shock body and mount the shock pump with its adaptor on the valve.
2. pump the recommended pressure into the shock. On the shock body you will find a table showing the recommended air pressure of the positive chamber according to the rider's weight.
3. when you reached the needed pressure remove the pump and put the valve cap on the valve
4. remove the valve cap of the negative valve (S9) which is the LOWER valve on the shock body and mount the shock pump with its adaptor on the valve
5. pump the recommended pressure into the shock. On the shock body you will find a table showing the recommended air pressure of the negative chamber according to the rider's weight.
6. when you reached the needed pressure remove the pump and put the valve cap on the valve

### Recommended Air Pressure

RIDERS WEIGHT		AIR PRESSURE POSITIVE		AIR PRESSURE NEGATIVE	
KG	LBS	BAR	PSI	BAR	PSI
40	88	11.0	160	8.0	116
45	99	12.0	174	8.5	123
50	110	13.0	189	9.0	131
55	121	14.0	203	10.0	145
60	132	15.0	218	10.5	152
65	143	16.0	232	11.0	160
70	154	17.0	247	12.0	174
75	165	18.0	261	12.5	181
80	176	19.0	276	13.5	196
85	187	20.0	290	14.0	203
90	198	21.0	305	14.5	210
95	209	22.0	319	15.5	225
100	220	23.0	334	16.0	232

## SAG

The SAG should be 12.5mm on the shock piston, which means approx. 25% SAG in Full Travel Position

To check the adjustment, please follow as shown below:

1. Sit on the bike, put your feet on the pedal.
2. check if the arrow of the SAG indicator matches with the 25% indication on the mudguard.
  - (In case you want go for a harder set up you could go for 20% SAG, in case you want to go for a softer set-up you could go for 30% SAG as shown as well on the indicator)
  - If the arrow matches with the SAG percentage indication of your choice the air pressure is matching to your weight
  - If the arrow is at a lower percentage indication then the one of your choice the air pressure I the positive air chamber is too high and should be carefully reduced by using the bleed knob of the shock pump until the arrow matches with the SAG percentage of your choice
  - If the arrow is at a higher percentage indication then the one of your choice the air pressure I the positive air chamber is too low and should be increased by using the shock pump until the arrow matches with the SAG percentage of your choice

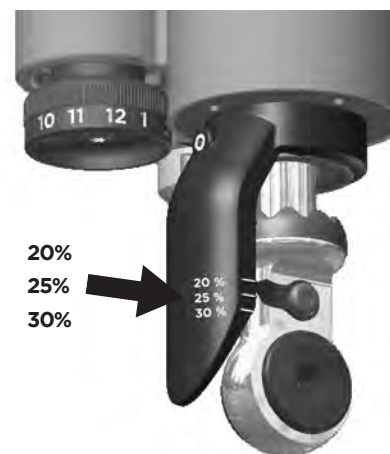

## SET-UP OF REBOUND EQUALIZER 2 SHOCK

“Rebound” describes the speed the shock comes back to its original length after absorbing an obstacle.

To adjust the rebound of the Equalizer 2 please follow the steps mentioned below:

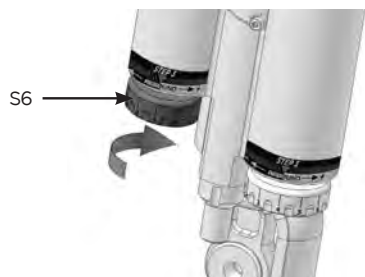

By using the red rebound screws (S6 & S7) on the downside of the Air Chambers you can adjust the rebound step by step.

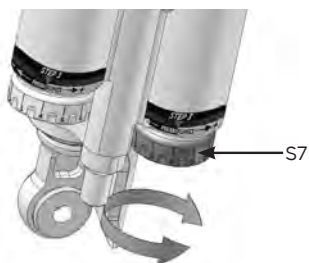

Please refer to the following instruction:

Ride your bike off a pavement (remain in the saddle) and check how many times it bounces.

- if it bounces 1-2 times, the set up is good.
- If it bounces more than 3 times the rebound is too fast.  
Turn both screws 1-2 “clicks” clockwise
- If it does not bounce the rebound is too slow.  
Turn both screws 1-2 “clicks” counter clockwise.

### Important:

Please make sure that both rebound wheels show the same number below the arrow on the shock body.

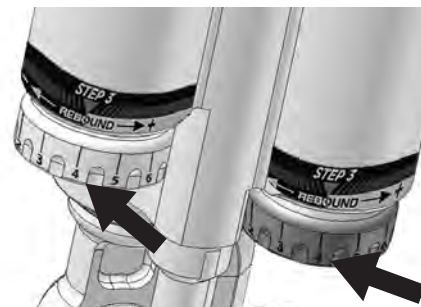

In case you want even more detailed figures of air pressure or tuning hints, you can download a program under [www.scott-sports.com](http://www.scott-sports.com) as a MS Excel file.

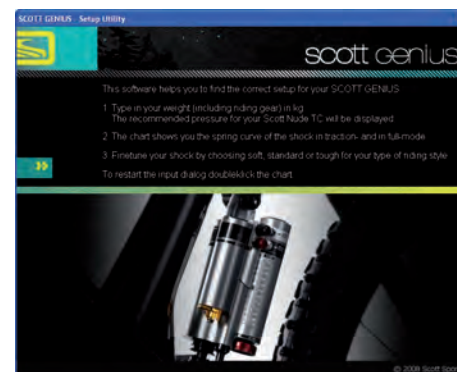



**Important:**

Note that you have to mount the Scott Equalizer 2 Shock always as shown beneath. Mounting the rear shock in a different position can cause severe damages to the frame, the linkage levers and the rear shock.

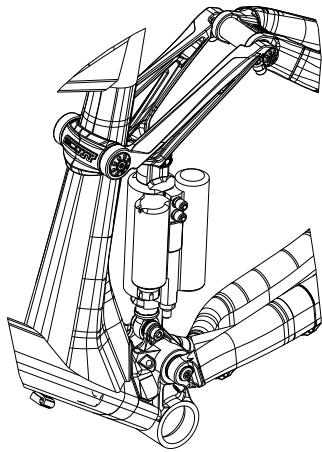
**Important:**

After a dismantlement of the rear shock, both fixing bolts should be tightened with a tightening torque of 5Nm/44in-lbs. If this is not done correctly the rear shock can be damaged.

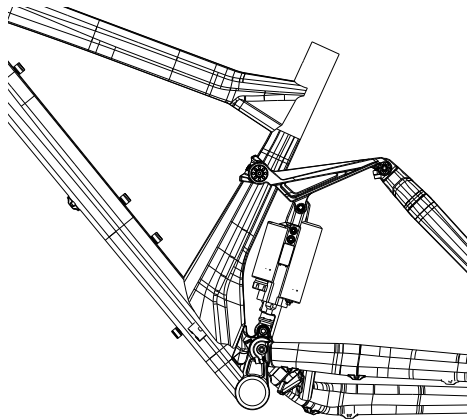

## SET-UP OF OTHER SHOCK MODELS

**Scott strongly recommends using only the Scott Equalizer 2 Shock with the Genius bike,** as we designed both parts for a perfect matching combination with a linear suspension rate.

If you want to use a different rear shock model than the one originally on the bike, please make sure that the shock will not in any position hit the frame and cause a damage to the frame.

Please follow the instruction below:

Please make sure that the rear shock or its accessory parts do not touch the frame when mounting or suspending.

For doing so release the air/remove the coil, install the shock and extend the shock completely.

If the shock touches the frame while doing so, do not use this shock in order to avoid damage to frame, swingarm or shock.

## SCOTT SMART CABLE ROUTING

The direct and straight cable system on all our full suspension models allows Smart Cable Routing which is very resistant against water and dirt.

To change the cables simply unscrew and open the cable brackets on the downtube.

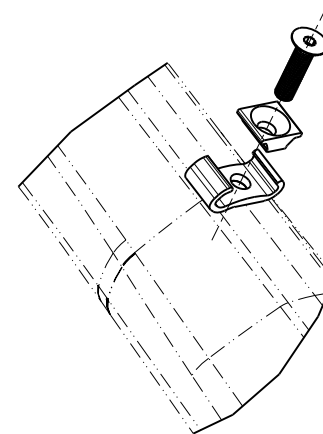

## CABLE HOUSING LENGTH

In order to avoid damages on the frame/derailleur and/or “ghost-shifting” which could result in dangerous riding please note that under the BB housing the distance between the cable housing and the BB shell should be minimum 35mm.

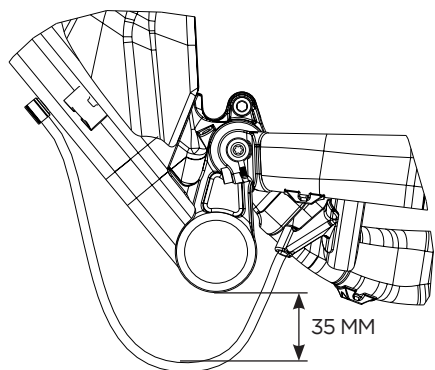

## ADJUSTMENT OF SEATPOST-HEIGHT

### Important:

The seatpost has to be inserted into the seattube at a minimum of 100mm.

Never use another seatpost diameter than 34.9mm or try to use a shim/reducer between seatpost and frame.

## REPLACEABLE DROPOUT

On Genius bikes you can replace the rear derailleur hanger.

In case the replaceable hanger is damaged by a crash or accident you can order at your local Scott dealer the replacement part with Scott article number 206473



## FRONT DERAILLEUR FIXATION

On Genius you will find an E-type front derailleur but fixed directly on the swingarm without the plate that is fixed normally between the bottom bracket bearing cup and the bottom bracket housing of the front triangle.

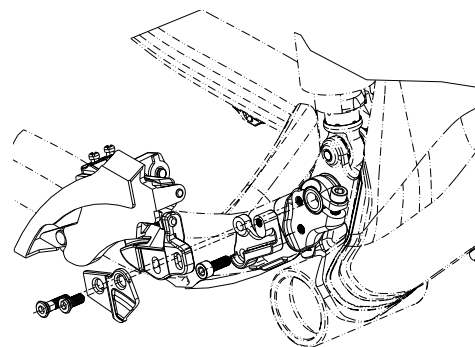

## FRONT FORK SET-UP/ CHANGE OF FRONT FORK

---

For the set up of the front fork please use the fork specific manual attached to the bike. We recommend using front forks with a travel of 140 - 150mm (518 - 525mm from mid of axle - top of crown), as this will not influence the geometry and alter handling of the bike.

## PIVOT MAINTENANCE

---

The pivot and bearings on SCOTT Genius are extremely easy to maintain. An external treatment with a grease spray after every bike wash is all you have to do. We do not recommend heavy grease sprays since these will leave a film on the parts which is difficult to remove. We recommend the same for the chain also.

If you have to change the bearings you can order them included in a service kit at your local SCOTT dealer or buy them with international parts number as shown above in the specs list in a hardware store.

In case of a change of the bearings or of the rear swingarm you should contact your local SCOTT dealer as you need special tools for disassembly and assembly.

## NOTES

---

.....

.....

.....

.....

.....

.....

.....

.....

.....

.....

.....

.....

.....

.....

.....

.....

.....

.....

.....

.....

.....

.....

.....



## WARRANTY

Model .....

Year .....

Size .....

Frame Nr. ....

Shock Nr. ....

Date of purchase .....

## WARRANTY

SCOTT bikes are made using the most innovative production and quality methods. They are equipped with best components of well known parts suppliers.

Doing so SCOTT warrants its frames and swingarms for five years (subject to compliance with maintenance ranges, see below) and SCOTT forks (provided it is a fork of SCOTT) for two years for defects in material and/or workmanship in case of purchase of completely assembled bikes.

This warranty of 5 years for the frames shall only be granted in case once a year a maintenance service has been effected according to maintenance requirements as set forth in this manual by an authorised SCOTT dealer.

The authorised SCOTT dealer shall confirm the effected annual maintenance service by stamp and signature.

In case such an annual maintenance service has not been effected the warranty of 5 years for the frame shall be reduced to 3 years.

Costs for maintenance and service have to be born by the owner of the SCOTT bike.

On Gambler, Voltage Fr and Volt-X the warranty period is limited to 2 years.

The warranty period starts at the day of purchase. This warranty is limited to the first buyer, what means the first person who uses the bike and only with the use it was made for. Furthermore, this warranty is limited to purchases via authorized SCOTT-dealers

The warranty is solely granted in case of purchase of a completely assembled bike to the explicit exclusion of purchases of not completely assembled bikes.

In case of a warranty claim the decision to repair or to replace the defective part is up to SCOTT. Non defective parts will only be replaced at the guarantee's own expense.

Fair wear and tear is not covered by the warranty.

A complete list of all parts of wear and tear can be found in the next chapter of this manual.

In addition, you will find at the end of this manual a protocol for the handing over of the bike which will remain in copy at the SCOTT dealer after acceptance and signature of the consumer.

It is obligatory to show this protocol of handing over together with the defective part in case of a warranty claim given that it provides evidence of purchase. Otherwise no warranty is granted.

In principle, this warranty is granted worldwide. Claims must be made through an authorized dealer, for information regarding the nearest dealer, write or call this company or the national SCOTT distributor.

Normal wear, accident, neglect, abuse, improper assembly, improper maintenance by other than an authorized dealer or use of parts or devices not consistent with the use originally intended for the bicycle as sold are not covered by this warranty.

Hereby SCOTT grants a voluntarily manufacturer's warranty. Additional entitlements according to national warrant of merchantability are reserved.

For warranty info on the Equalizer 2 shock please refer to the attached manual of DT Swiss.

