



**GENIUS**

**SCOTT 2013 BIKE OWNERS  
MANUAL**

SCOTT SPORTS SA | 17 RTE DU CROCHET | 1762 GIVISIEZ | SWITZERLAND  
© 2011 SCOTT SPORTS SA, ALL RIGHTS RESERVED | SCOTT-SPORTS.COM





The Genius should be adjusted exactly to the current rider for reaching maximum safety and fun while riding. All adjustments should be done at the local Scott dealer or following to this manual. In order to avoid technical problems or any harm please contact in case of doubts your authorized Scott dealer.

## CONTENT

---

Genius Concept .....	P. 004
Geometry/Technical Data Genius 650B/27.5" .....	P. 005
Geometry/Technical Data Genius 29" .....	P. 007
TC Shock Technology/TWINLOC XL Levers .....	P. 009
Basic Set-Up of the TWINLOC Remote Control .....	P. 014
Recommended Tools for the Shock Set-Up .....	P. 019
Set-Up Genius with Scott Nude 2 TC Shock .....	P. 020
Headset Options .....	P. 024
Bottom Bracket Of Genius .....	P. 025
Adjustable BB Height/Angle Adjustment .....	P. 026
Front Derailleur Assembly .....	P. 027
Chainguide Systems .....	P. 028
Genius Cable Routing .....	P. 030
Adjustment of Seatpost-Height .....	P. 030
Replaceable Drop Out Systems .....	P. 035
Rear Brake Assembly .....	P. 035
Front Fork Set-Up/Change of Front Fork .....	P. 036
Pivot Maintenance .....	P. 036
Warranty .....	P. 039

# GENIUS CONCEPT

The new Genius is the result of 2 years of research and development for one of the lightest trail/marathon bike frame set available on the market, hitting the scale at below 2300 grams (5 lbs) including the frame, Scott Nude 2 /DT M3 shock and the unique TWINLOC XL remote control.

Scott's focus was not only on lightweight but also on a durable and stiff frame with an innovative suspension technology in combination with an optimized kinematics of the rear swingarm.

The combination of an optimized kinematics with an extraordinary suspension technology closes the gap between superlight dual suspension race bikes (e.g. Scott Spark) and the new generation of all-mountain bikes (e.g. Scott Genius LT).

Genius was designed for riders looking for a dual suspended trail and marathon bike offering a maximum rear wheel travel of 150mm (27.5")/130mm (29").

Scott does not see frame and rear shock as single components which are assembled together on a bike, but as a concept with all these components working together and offering an outrageous function by matching perfectly.

The Genius Concept is based on a multi-pivot technology.

The damping performance was improved in comparison to the already famous "old" Genius, and with reworking also the kinematics we were able to reach a better progression in the end of the stroke/travel of the swingarm.

The Scott system, using the Nude 2 shock, named TC (Traction Control) will allow you to reduce by remote control the rear wheel travel from 150 (27.5")/130 (29")mm to 100 (27.5")/90(29")mm including a more progressive spring rate but still offering a supple break away.

Some models of Genius use also the DT M3 shock which offers instead of the Traction Mode a Platform (Ride Mode) in between Lock-out Mode and Descent Mode

No power will be lost and an optimum power transfer is guaranteed as the swingarm, in contrary to locked or automatic-locking systems, can follow the trail surface and will offer perfect traction and higher speed while standing on the pedals.

# GEOMETRY GENIUS 700

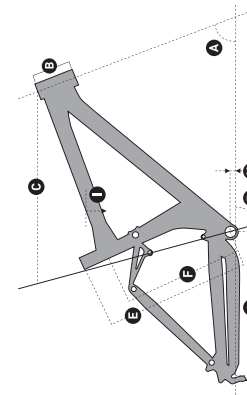

	A	B	C	D	E	F	G	H	I	I	I	I	D
Size	Head angle	Head tube length	Effective top tube horizontal	Seat angle	BB center to top of seat tube	Chainstay length	BB offset	BB height	Standover height	Wheel base	Reach	Stack	Stem length
	°	mm inches	mm inches	°	mm inches	mm inches	mm inches	mm inches	mm inches	mm inches	mm inches	mm inches	mm
<b>GENIUS 700 LOW POSITION</b>													
S	67.7°	100 3.9	570 22.4	73.8°	415 16.3	440 17.3	-0	346 13.6	776 30.6	1124 44.3	399 15.7	590 23.2	60
M	67.7°	110 4.3	600 23.6	73.8°	440 17.3	440 17.3	-0	346 13.6	777 30.6	1155 45.5	427 16.8	599 23.6	70
L	67.7°	120 4.7	625 24.6	73.8°	475 18.7	440 17.3	-0	346 13.6	809 31.9	1181 46.6	449 17.7	609 24.0	80
XL	67.7°	135 5.3	650 25.6	73.8°	510 20.1	440 17.3	-0	346 13.6	815 32.1	1208 47.6	470 18.5	623 24.5	90
<b>GENIUS 700 HIGH POSITION</b>													
S	68.2°	100 3.9	570 22.4	74.3°	415 16.3	440 17.3	-4	352 13.9	776 30.6	1124 44.3	404 15.9	587 23.1	60
M	68.2°	110 4.3	600 23.6	74.3°	440 17.3	440 17.3	-4	352 13.9	777 30.6	1155 45.5	431 17.0	596 23.5	70
L	68.2°	120 4.7	625 24.6	74.3°	475 18.7	440 17.3	-4	352 13.9	809 31.9	1181 46.6	454 17.9	605 23.8	80
XL	68.2°	135 5.3	650 25.6	74.3°	510 20.1	440 17.3	-4	352 13.9	815 32.1	1208 47.6	475 18.7	619 24.4	90

# TECHNICAL DATA GENIUS 700

Travel	150/100/0mm
Suspension Ratio	2.72
Piston Stroke	55mm
Shock Length (Eye to Eye)	200mm
Hardware Mainframe	22.2mm x 6mm
Hardware Swingarm	22.2mm x 6mm
Seatpost Diameter	31,6mm
Headset	semi integr. for tapered 1 1/8-1.5 (44/54.9mm Inner diameter of frame) or with 1 1/8 straight (44.0mm)
Fork Travel	150mm
Fork Length	544mm
BB Housing	BB PF 92
Front Derailleur	Shimano E-Type/SRAM S3 direct mount
Bearings	2 x IGUS /
	6 x 6802 (24 x 15 x 5)
Max. Tire Width	57mm/2.25inch

# GEOMETRY GENIUS 900

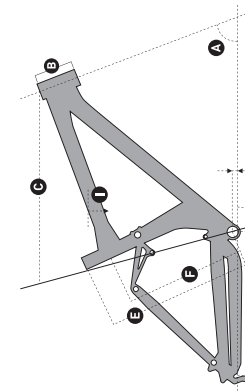

Size	A	B	C	D	E	F	G	H	I	I	I	I	D
	Head angle	Head tube length	Effective top tube horizontal	Seat angle	BB center to top of seat tube	Chainstay length	BB offset	BB height	Standover height	Wheel base	Reach	Stack	Stem length
	°	mm inches	mm inches	°	mm inches	mm inches	mm inches	mm inches	mm inches	mm inches	mm inches	mm inches	mm

## GENIUS 900 LOW POSITION

S	69.0°	100	3.9	570	22.4	74.0°	415	16.3	450	17.7	-35	-1.4	335	13.2	766	30.2	1111	44.7	395	15.6	609	24.0	60
M	69.0°	100	3.9	600	23.6	74.0°	440	17.3	450	17.7	-35	-1.4	335	13.2	772	30.4	1141	44.9	425	16.7	609	24.0	70
L	69.0°	110	4.3	625	24.6	74.0°	475	18.7	450	17.7	-35	-1.4	335	13.2	801	31.5	1167	45.9	448	17.6	618	24.3	80
XL	69.0°	120	4.7	650	25.6	74.0°	510	20.1	450	17.7	-35	-1.4	335	13.2	808	31.8	1193	47.0	470	18.5	628	24.7	90

## GENIUS 900 HIGH POSITION

S	69.5°	100	3.9	570	22.4	74.5°	415	16.3	450	17.7	-30	-1.2	341	13.4	766	30.2	1111	44.7	400	15.7	606	23.9	60
M	69.5°	100	3.9	600	23.6	74.5°	440	17.3	450	17.7	-30	-1.2	341	13.4	772	30.4	1141	44.9	430	16.9	606	23.9	70
L	69.5°	120	4.3	625	24.6	74.5°	475	18.7	450	17.7	-30	-1.2	341	13.4	801	31.5	1167	45.9	453	17.8	615	24.2	80
XL	69.5°	135	4.7	650	25.6	74.5°	510	20.1	450	17.7	-30	-1.2	341	13.4	808	31.8	1193	47.0	475	18.7	624	24.6	90

## TECHNICAL DATA GENIUS 900

Travel	130/90/0mm
Suspension Ratio	2.60
Piston Stroke	50mm
Shock Length (Eye to Eye)	190mm
Hardware Mainframe	22.2mm x 6mm
Hardware Swingarm	22.2mm x 6mm
Seatpost Diameter	31,6mm
Headset	semi integr. for tapered 1 1/8-1.5 (44/54.9mm Inner diameter of frame) or with 1 1/8 straight (44.0mm)
Fork Travel	130mm
Fork Length	540mm
BB Housing	BB PF 92
Front Derailleur	Shimano E-Type/SRAM S3 direct mount
Bearings	2 x IGUS / 6 x 6802 (24 x 15 x 5)
Max. Tire Width	57mm/2.25inch

## TC SHOCK TECHNOLOGY/TWINLOC XL LEVERS

The heart of the TC-System is the Scott Nude 2 Shock made by DT Swiss, offering three functions which make this system possible.

The TWINLOC XL remote control lever is the evolution of the already outstanding TRACLOC system of Scott.

While TRACLOC allowed only the change on the Scott TC rear shocks between the Scott patented Lock-out, traction and full-mode on the fly from the handlebar, the TWINLOC allows also the remote control of the front fork to shift between lock-out and open mode at the same time when you change the modes on the Scott rear shox. In combination with FOX 34 CTD (27.5")/ FOX 32 CTD (29") forks it is also possible to have a platform mode on the fork.

The 3 modes of LTD in combination with Nude 2 are:

- **L**ock-out Mode : lock-out rear, lock-out front
- **T**raction Mode: traction mode rear, platform mode front
- **D**escent Mode: full travel rear (Descent), full travel front

The 3 modes of LRD in combination with the DT M3 shock are:

- **L**ock-out Mode : lock-out rear, lock-out front
- **R**ide Mode: platform(Ride) mode rear, platform mode front
- **D**escent Mode: full travel rear (Descent), full travel front

Therefore Scott offers 2 different TWINLOC XL levers with following fork/rear shock combinations:

- Nude 2 with different rolls for FOX CTD fork and RockShox DNA 3 fork (Scott Article number: 230097)
- DT M3 with different rolls for FOX CTD fork and RockShox DNA 3 fork (Scott Article number: 230098)

Please note that the DT Swiss M3 rear shock does not offer a traction mode, but a platform mode. In contrary to Nude 2 the air-chamber volume of the positive chamber remains the same throughout the different modes

### Important:

You can only assemble the TWINLOC XL remote lever in "left side upward position" on the handlebar.

You have 3 positions of the TWINLOC XL remote lever.

### 1. LOCK OUT MODE:

the shock is locked; climbing on asphalt roads is now possible without any power loss. Simultaneous a blow-off-system prevents the shock being damaged in case the rider did not open the system while crossing obstacles.

### 2. TRACTION/RIDE MODE:

For Traction: by reducing the internal chamber volume inside the shock the travel of the shock will be reduced to around 60% (approx. 100/90mm) the characteristic of the air spring gets harder. This results in climbing without "bobbing" and offers still optimum traction of the rear wheel.

For Ride: by adding a platform on the compression damping system the shock will not bounce while standing on the pedals

### 3. DESCENT MODE:

full travel of 150/130mm (27.5"/29")

You will find the following positions on the remote lever:

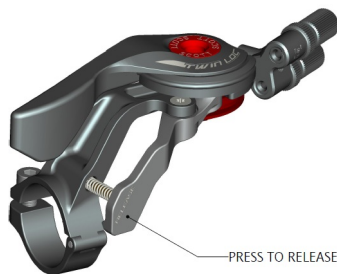
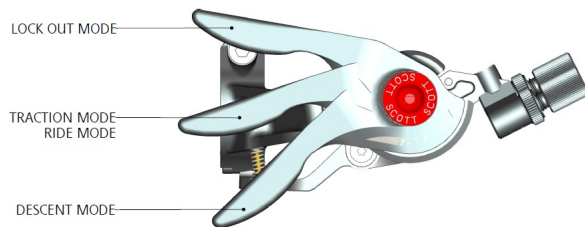

For the assembly of the remote control of the front fork lock-out 2 different changeable cable rolls are existing.

The different roll for the pull of the fork remote cable can be changed within few minutes to adapt the lever to your fork model/brand.

You will see on the downside of the roll the indication of the fork brand or the fork model.

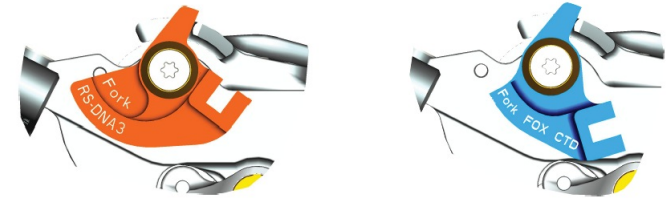

Scott offers 2 different TWINLOC XL levers with following fork/rear shock combinations:

- Nude 2 with different rolls for FOX CTD fork and RockShox DNA 3 fork (Scott Article number: 230097)
- DT M3 with different rolls for FOX CTD fork and RockShox DNA 3 fork (Scott Article number: 230098)

**Please kindly note that the cable roll of a RockShox DNA3 or FOX CTD fork-lever is not interchangeable with the regular rolls of 2 step forks. You need to use another lever!**

**For more details please contact your authorized Scott dealer.**

To change the rolls to match another fork brand pls follow the drawings below:

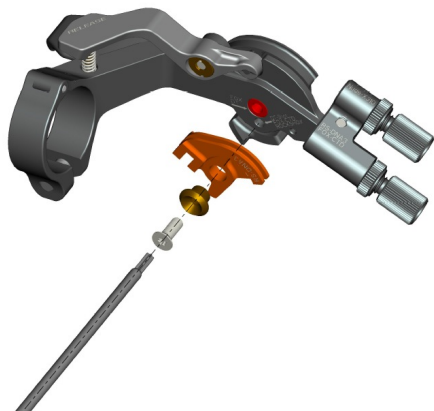
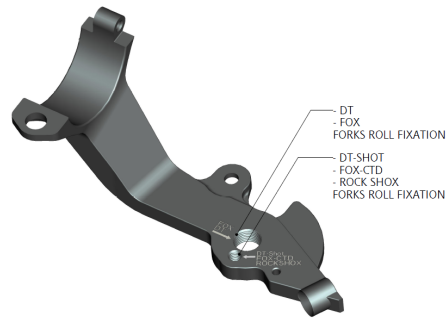
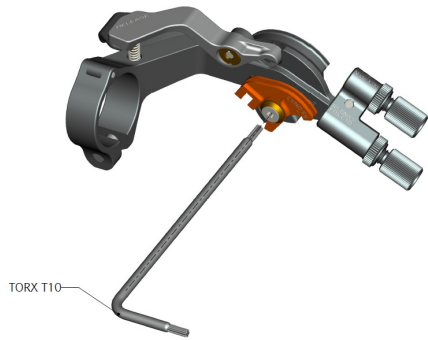

## ASSEMBLY OF THE REMOTE CABLE

### Important:

Please make sure the lockout of SRAM/RockShox or FOX fork is activated after transport correctly. Therefore please compress fork 5-10 times before following the manual on remote cable installation and adjustment.

The lever should show on the downside of the cable roll the brand name of the fork you are going to use. Please do not try to use a RockShox roll with a FOX fork or vice versa.

1. To assemble the cable please bring the lever into the Descent Mode, push the cable into the lever-eyelet as shown on drawing below, push it through the pre-cut cable housing and fix it at the assembly unit on top of the right side of the fork crown.

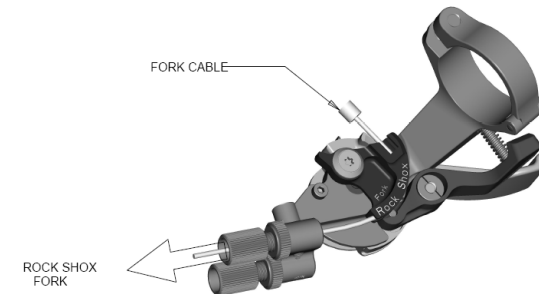

2. Fix the cable with the 2mm allen screw on the barrel adjuster on the fork crown with a tightening torque of 0.9Nm/8 lb/in, cut the cable and secure it with a cable end-cap. Please refer for this action also to the manual of SRAM/RockShox or FOX attached to the bike.

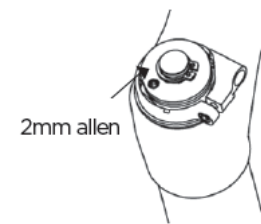

### TIP:

To check for accurate cable tension, please try to move the plastic end cap of the cable housing at the barrel adjuster on the remote lever. There should be "no-play" between cap and barrel adjuster.

In case of "play" please turn the barrel adjuster clockwise until "no-play".

## NUDE 2 SHOCK AND TWINLOC XL REMOTE CONTROL LEVER

In the drawing of the shock and remote lever, shown below, you will see the parts indicated with numbers which will be used in the manual for the adjustment and set-up.

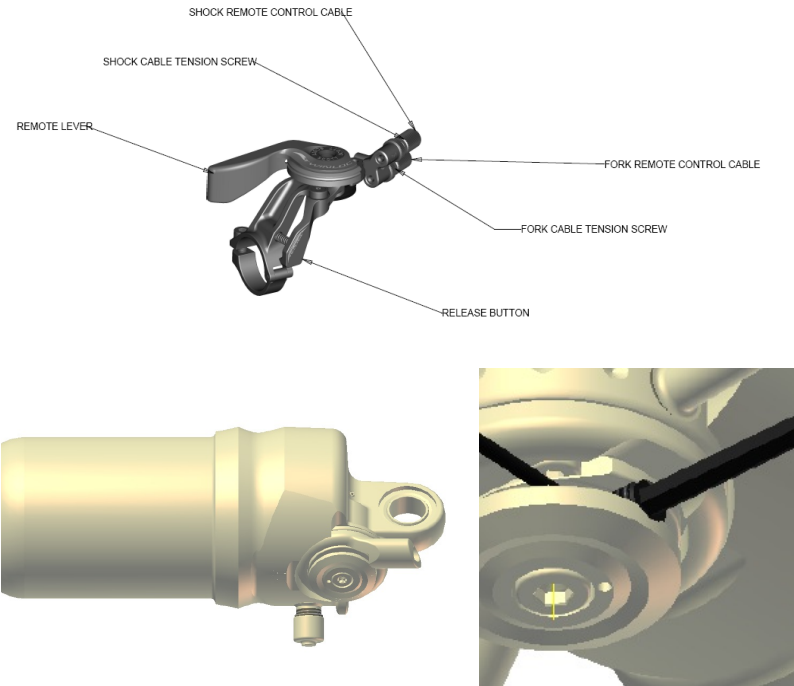

S1	Front eyelet/ Shock Bolt	L1	Remote Lever
S2	Rear eyelet/ Shock Bolt	L2	Release button
S3	Shock Housing	L3	Remote Control Cables
S4	Rebound-Adjuster Knob	L4	Cable Tension Screw Fork Remote
S5	Positive Chamber Valve	L5	Cable Tension Screw Shock Remote
S6	Remote Control Wheel		
S7	Cable Fixing Screw (hidden behind remote wheel)		
S8	Shock Piston		
S9	SAG Indicator (o-ring on piston)		

## BASIC SET-UP OF THE TWINLOC XL REMOTE CONTROL OF NUDE 2 SHOCK

To ensure perfect function of the Nude 2 TC shock it is very important to follow the steps shown below exactly.

On Genius Carbon frames you will find an internal cable routing.

Push the inner cable first through the remote lever in the upper cable routing of the lever and then through the cable housing as shown below inside the toptube.

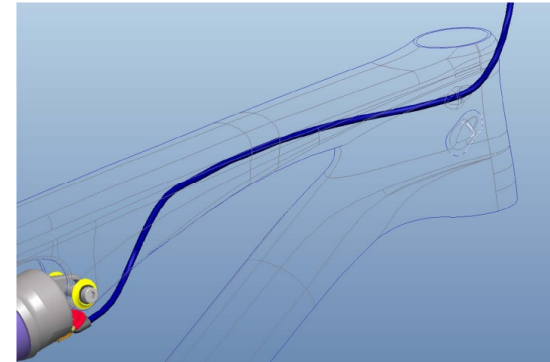

On Genius alloy frames a regular outside cable routing, the outer cable housing is fixed on cable mount ports with cable zippers.

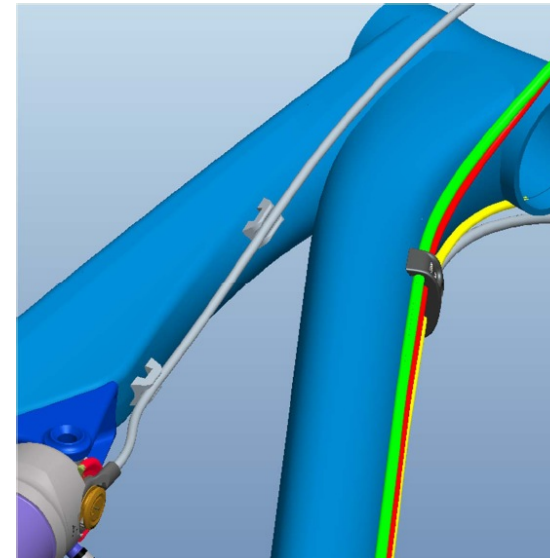



1. loosen the cable fixing screw (S7) by turning it counter clockwise with a 2mm allen key.

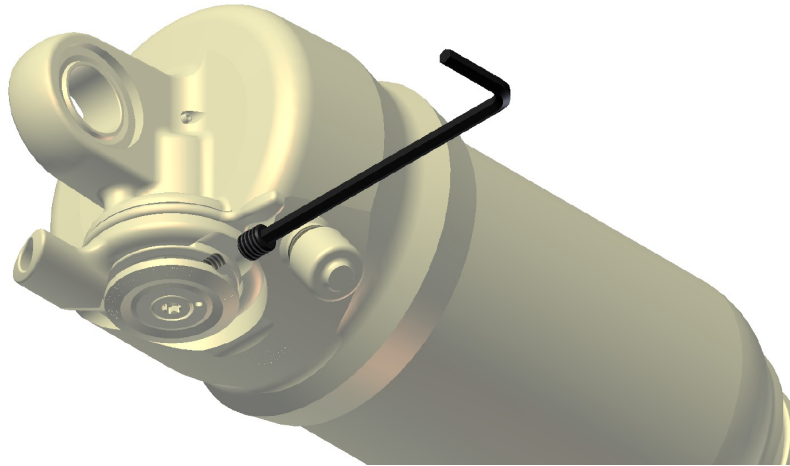

2. insert a new cable via lever hole and cable housing and push it into the shock as shown around the remote wheel (S6).

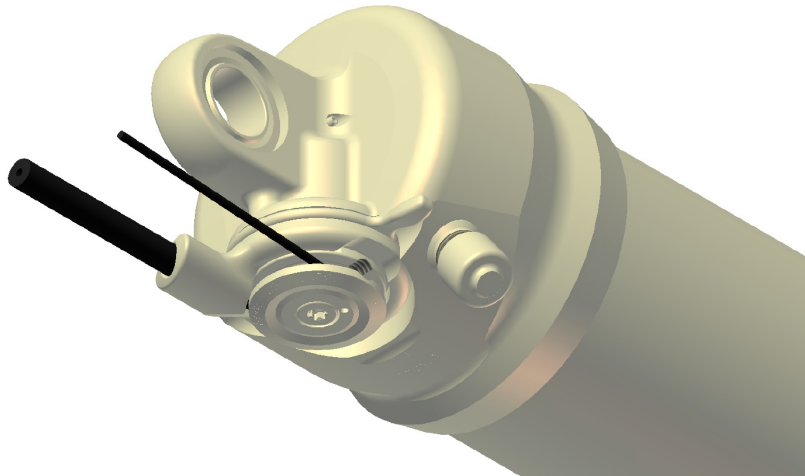

3. tighten the cable and fix the cablefixing screw (S7) by turning it clockwise with a 2mm allen key and a **max. tightening torque of 1.6Nm.**

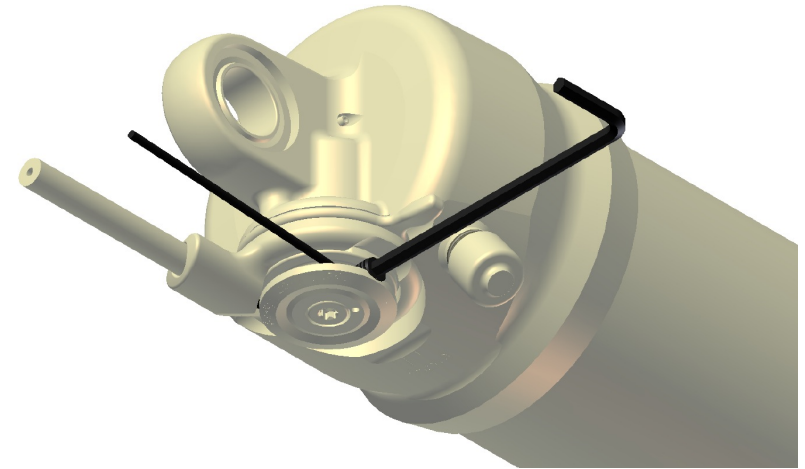

4. cut the cable approx. 20mm away from the remote wheel. Fix it by squeezing it with pliers.

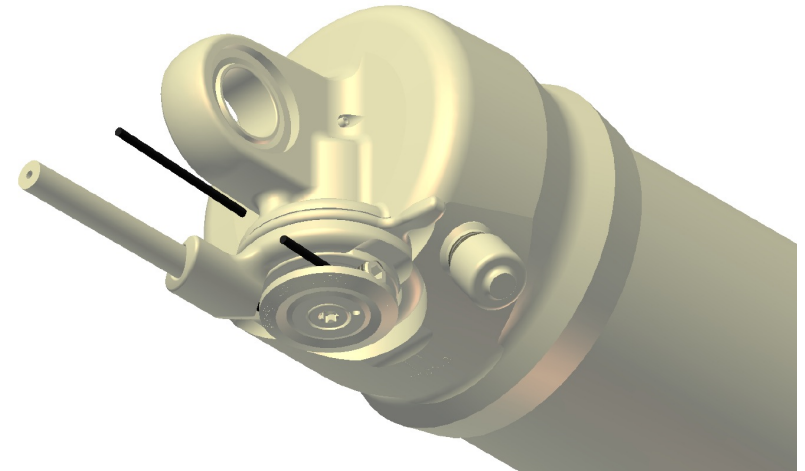

5. Fix it by squeezing it with pliers.

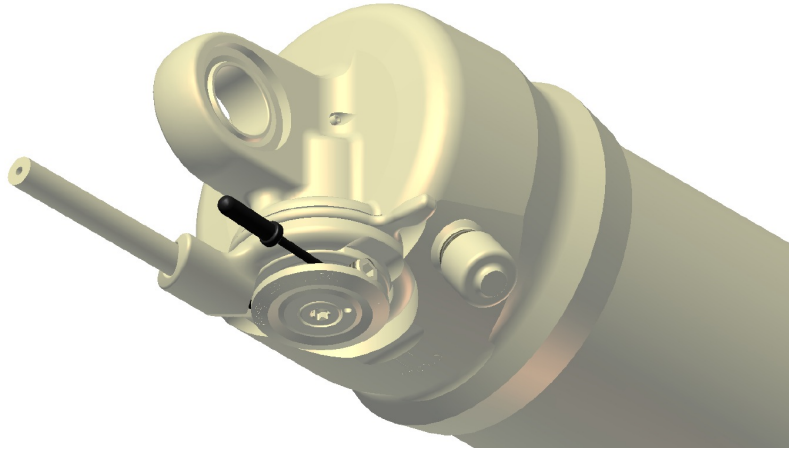

## BASIC SET-UP OF THE TWINLOCXL REMOTE CONTROL OF DT M3 SHOCK

The assembly of the remote cable and the setup of the M3 rear shock is very similar to the abovementioned assembly and setup of the Nude2

For more details on the DT M3 please follow the details shown in the manuals of DT Swiss attached to this bike.

## RECOMMENDED TOOLS FOR THE SHOCK SET-UP

For the set-up of the shock we recommend to use a shock pump with a scale up to 20 bars/300 psi with a special air valve connector preventing from air getting away while removing the pump from the shock valve, this will result in an exact air pressure.

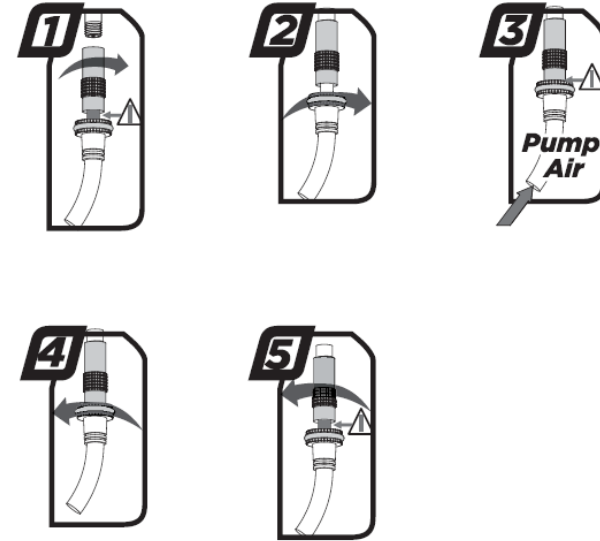

Please note that air will flow into the hose and indicator when counterchecking the air pressure, so you have to set up again the recommended pressure after this action.

Make sure to balance at least this air loss when you make a check of the air pressure of the shock. Pls also note that the indicators of shock pumps have a tolerance of max. 10%.

## SET-UP GENIUS WITH NUDE 2 OR DT M3 SHOCK

The Set-Up of the Scott Nude 2 or DT M3 Shock can be easy done within a few minutes.

### Important:

For all adjustments of the air spring the remote lever has to be in position "all travel"

To adjust the air pressure of the air chamber of the Scott Nude 2 or DT M3 Shock please refer to the following instruction:

1. remove the valve cap of the valve (S5) located on the shock housing (S3).
2. mount the shock pump with its adaptor on the valve
3. pls take into account that it takes some air pressure from inside the shock to drive the indicator on the pump. Make sure to balance at least this air loss when you make a check of the air pressure of the shock. Pls also note that the indicators of shock pumps have a tolerance of max. 10%
4. pump the recommended pressure into the shock. On the shock you will find a decal showing the recommended air pressure of the positive chamber according to the rider's weight.
5. when you reached the needed pressure remove the pump and put the valve cap on the valve

## RECOMMENDED AIR PRESSURE

Genius Pressure Charts - For Manual, Naked Rider Weight			All Low Position				
			700	900			
kg/bar	45	4.1	3.1	99	700	59	44
	50	4.6	3.6	110	700	66	52
	55	5.1	4.2	121	700	74	60
	60	5.6	4.7	132	700	82	69
	65	6.2	5.3	143	700	90	77
	70	6.7	5.9	154	700	98	85
	75	7.3	6.5	165	700	106	94
	80	7.9	7.0	176	700	115	102
	85	8.5	7.6	187	700	123	111
	90	9.1	8.2	198	700	132	119
	95	9.8	8.8	209	700	142	128
100	10.4	9.5	220	700	151	137	
105	11.1	10.1	231	700	161	146	
110	11.8	10.7	242	700	172	155	

## SAG

The SAG should be 14mm (27.5/650B) respectively 12.5mm (29") on the shock piston.

To check the adjustment, please follow as shown below:

1. sit on the bike, put your feet on the pedal
2. put your feet back on the ground and stand over the bike without bouncing the bike during this action
3. check if the o-ring (S9) on the shock piston (S8) has a distance of 14/12.5mm to the main dust wiper/seal between shock housing and piston.

- if the distance between the o-ring and the main dust wiper/seal is 14/12.5mm, the air pressure is matching to your weight
- if the distance between the o-ring and the main dust wiper/seal is less than 14/12.5mm, the air pressure of the air chamber is too high and should be carefully reduced by using the bleed knob of the shock pump until the distance is 14/12.5mm.
- if the distance between the main dust wiper/seal is bigger than 14/12.5mm the air pressure of the air chamber is too low and should be increased by using the shock pump until the distance is 14/12.5mm.

## SET-UP OF REBOUND NUDE 2 OR DT M3 SHOCK

"Rebound" describes the speed the shock comes back to its original length after absorbing an obstacle.

By using the rebound adjuster knob (S4) you can adjust the rebound step by step.

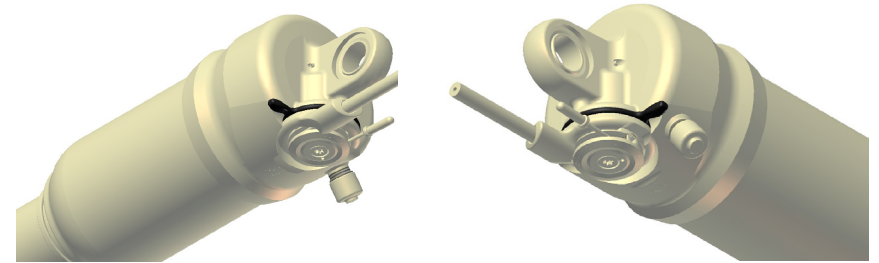

Please refer to the following instruction:

Ride your bike off a pavement (remain in the saddle) and check how many times it bounces.

- if it bounces 1-2 times, the set up is good.
- If it bounces more than 3 times the rebound is too fast. Turn the knob 1-2 "clicks" clockwise
- If it does not bounce the rebound is too slow. Turn the knob 1-2 "clicks" counter clockwise.

In case you want even more detailed figures of air pressure or tuning hints, you can download a program under [www.scott-sports.com](http://www.scott-sports.com) in the support area of the website

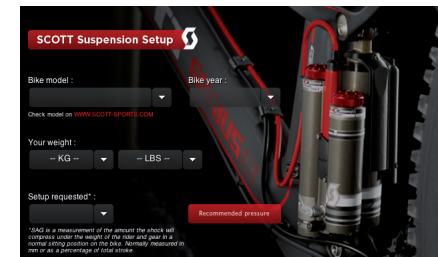

**Important:**

Note that you have to mount the Scott Nude 2 Shock always as shown underneath.  
Mounting the rear shock in a different position can cause severe damages to the frame, the linkage levers and the rear shock.  
Same for the DT M3 on some of the Genius models.

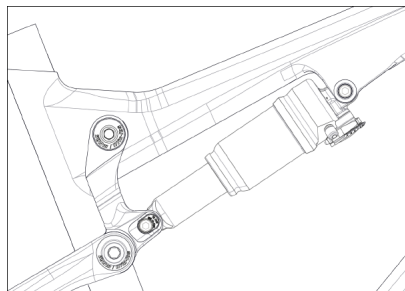

**Important:**

After a dismantlement of the rear shock, both fixing bolts should be tightened with a tightening torque of 5Nm/44in-lbs.  
If this is not done correctly the rear shock can be damaged.

## SET-UP OF OTHER SHOCK MODELS

Scott strongly recommends using only the Scott Nude 2 (DT M3 shock) with the Genius bike, as we designed both parts for a perfect matching combination with a linear suspension rate.

Also on those shock models the SAG should be 14/12.5mm.

Other Shock Models on Genius

If you want to use a different rear shock model than the one originally on the bike, please make sure that the shock will not hit the frame in any position and cause a damage to the frame.

Please follow the instruction below:

Please make sure that the rear shock or its accessory parts do not touch the frame when mounting or suspending.

For doing so release the air/remove the coil, install the shock and compress the shock completely.

If the shock touches the frame while doing so, do not use this shock in order to avoid damage to frame, swingarm or shock.

## HEADSET OPTIONS

Genius features a tapered headset and fork steerer system to match with semi-integrated headsets of the "50-61"mm range with ID of Headtube of 44.0mm on top and 54.9mm on the lower end.

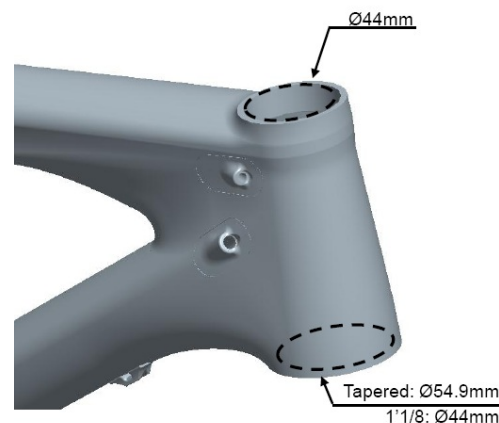

**Headset Pro Zero Logic Press Fit Taper 18mm**

9	Crown Race	1	Black
8	ACB Bearing	1	Black
7	Lower Cup	1	Black
6	Upper Cup	1	Black
5	ACB Bearing	1	Silver
4	Compressor Ring	1	Silver
3	Seal	1	Black
2	Top Cap	1	Black
1	O-Ring	1	Black
No.	Material	QTY	Remark

Scale	Drawing	Material	Date
Unit	mm	Part No.	PRD 13641 (OE)

Ritchey WCS Carbon Zero Tapered / PF 50-61mm / 18mm UD	PRD 13636
Ritchey PRO Tapered / PF 50-61mm / 12.9mm	PRD 13640

It is also possible to use forks with a standard 1 1/8" steerer tube when using a reducer headset such as e.g.

Ritchey WCS Carbon Zero Tapered / PF 50-61mm / 18mm UD for 1 1/8" fork	PRD 14860
--	-----------

## BOTTOM BRACKET (BB) ON GENIUS

All frames of Genius (carbon and alloy) have a BB shell for BB92PF standard.

This matches to several bearing and crankset models of Shimano, SRAM, FSA and others.

**Please note that you do not need anymore a spacer on the right side of the bearing cup between frame housing and bearing cup.**

BB (carbon frames): PF92 (ID41mm), no Spacer

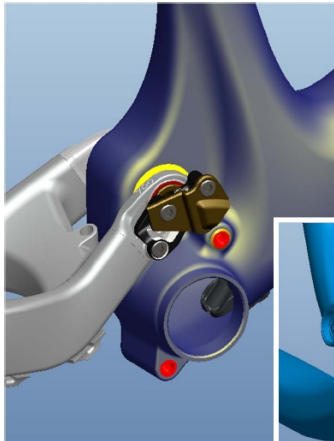

BB (alloy frames): PF92 (ID41mm), no Spacer

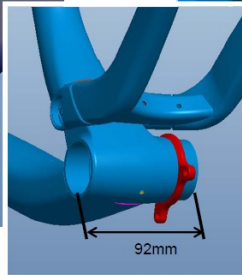
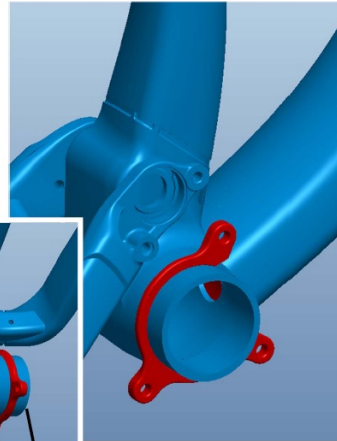

## ADJUSTABLE BB HEIGHT

On Genius bikes equipped with the Nude 2 or the M3 shock you can adjust the BB height above ground in 2 positions by flipping a geometry chip located on the linkage bar shock mount.

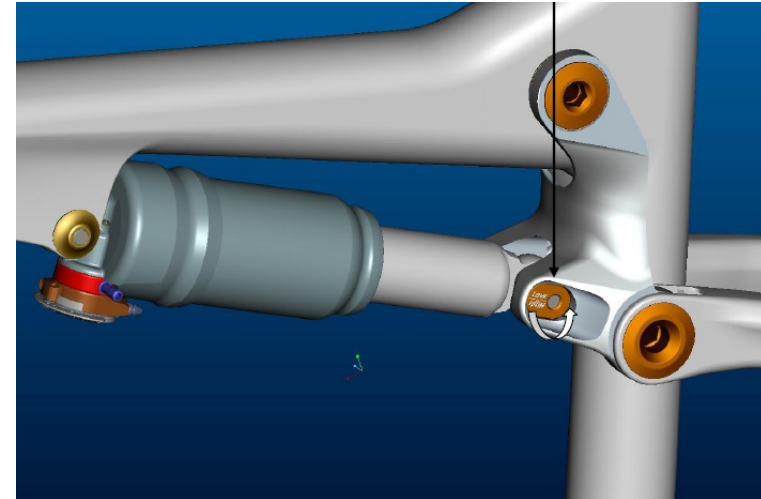

1. low BB for lower center of gravity over ground
2. high BB for bigger clearance between pedals/crankset and obstacles on the ground

Genius 700:

- head angle: 67.9° (low) - 68.4° (high)
- BB height: 345mm (low) - 351mm (high)

Genius 900:

- head angle: 69° (low) - 69.5° (high)
- BB height: 335mm (low) - 340mm (high)

### Important:

It is not possible to use this geometry chip with other shock models than the Nude 2 or M3.

The shock might collide with parts of the frame or linkage bar.

## FRONT DERAILLEUR (FD) MOUNTING DETAILS

On all Genius frames you will find a Shimano E-type front derailleur but fixed directly on the swingarm without the plate that is fixed normally between the bottom bracket and the bottom bracket housing of the front triangle or a SRAM Direct Mount Type S3 FD.

Please note that you always need to use the adapter plate attached to the bike or frame set between chainstay and front derailleur.

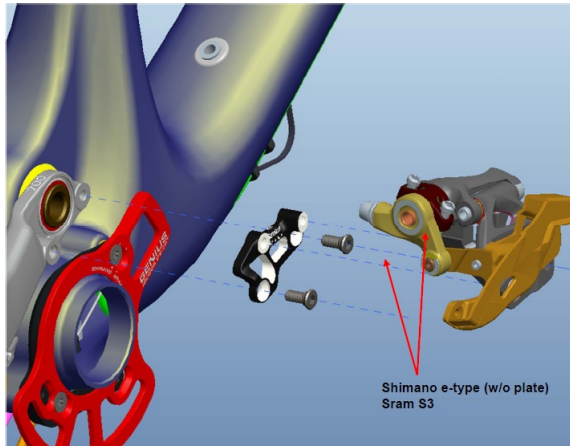

This adapter can be ordered at the Scott distribution with parts number:

229728	FD Mount Genius 2013 700-650B
229729	FD Mount Genius 2013 900-29

Please note that the 2 sizes of the adapters are not interchangeable!

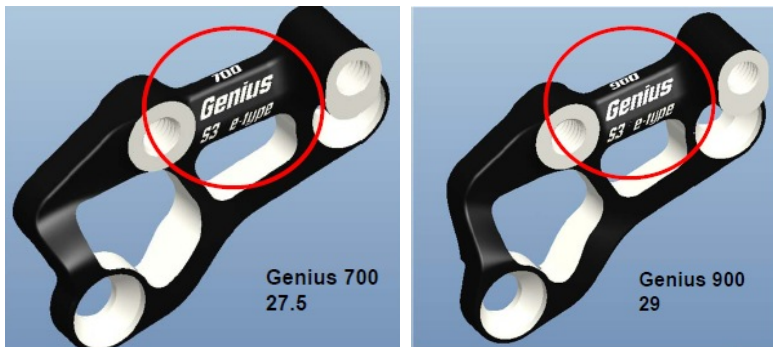

## CHAINGUIDE

The Carbon as well as the alloy frames of Genius can be fitted with ISCG chainguide systems.

A set of all spare parts for this action can be ordered via the Scott distribution with:

229730	ISCG adaptor Genius 2013
--------	--------------------------

Details for the assembly on the carbon frames of Genius:

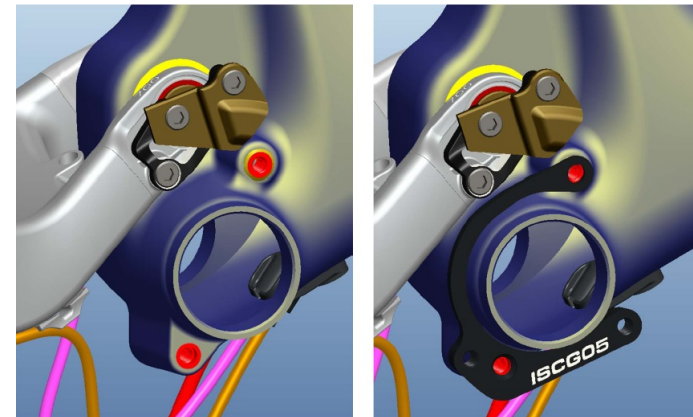

The adaptor must be used in order to assemble the chainblocker on the ISCG05 chainguide system.

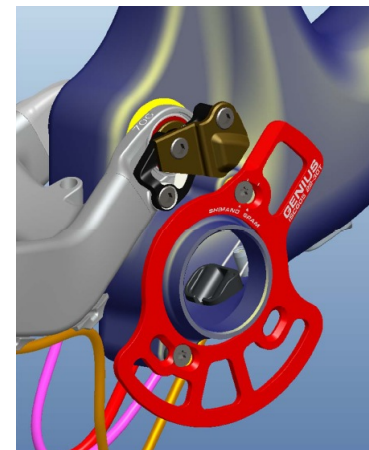

Please note that you need to assemble the chainblocker exactly the way as shown below and use all parts of the set.

Please also respect the different assembly positions for SRAM and Shimano front derailleurs

For 2x10 drivetrains you need to use 2x2.5mm washers, for 3x10 drive trains 1x2.5mm washers between adaptor/frame and the chainblocker as shown above.

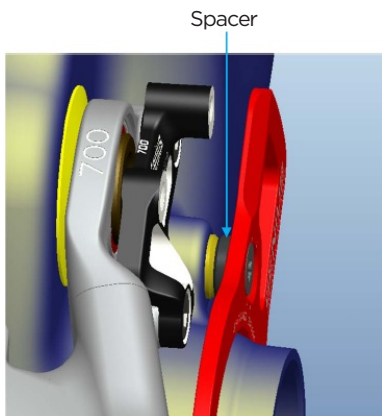

Details for the assembly on the alloy frames of Genius:

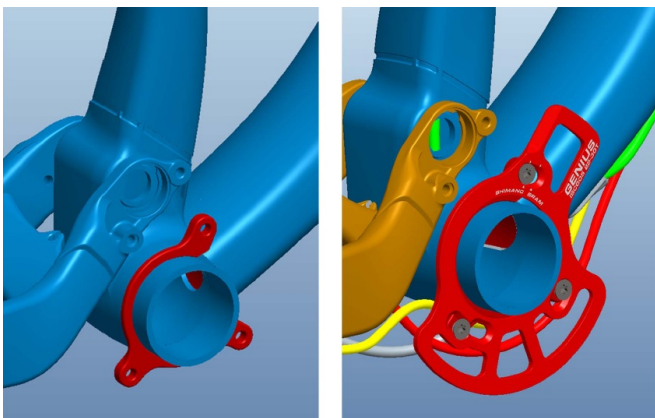

You can assemble the chainblocker directly on the integrated ISCG05 mount on the BB shell.

Please respect the different assembly positions for SRAM and Shimano front derailleurs.

## GENIUS CABLE ROUTING

The direct and straight cable system on all our full suspension models offers perfect shifting performance combined with lightweight and high resistance against water and dirt.

### Carbon Front frames:

The carbon frames of Genius have an internal shifting cable routing with cable stops on the front end of the downtube as shown in the drawing below.

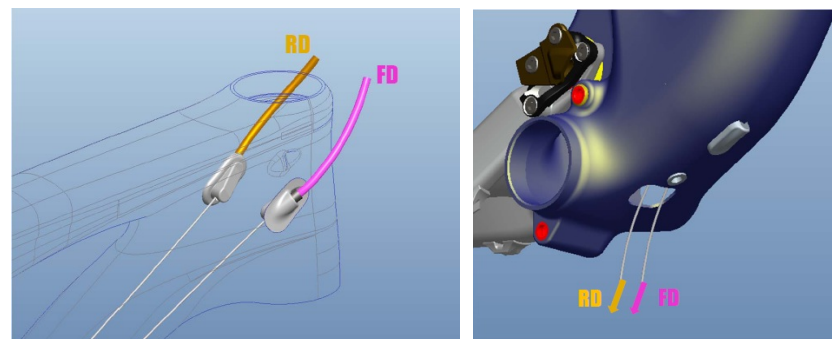

Please note that the inner cables need to cross each other 1 time on the inside of the downtube before you pull them out through the cable slot on the lower downside of the downtube.

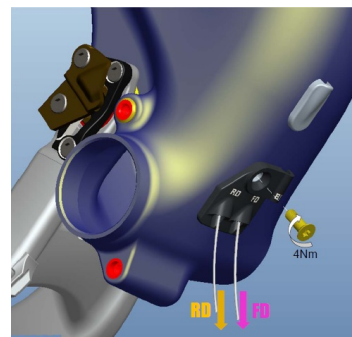

Push the cables through the cable guide as shown below and fix the cable guide on the downtube with a 3mm allen key and a tightening torque of max. 4Nm/35in/lbf.



Push the outer cable housings on the cables into the cable guide but make sure to respect the needed length as shown in the next drawing!

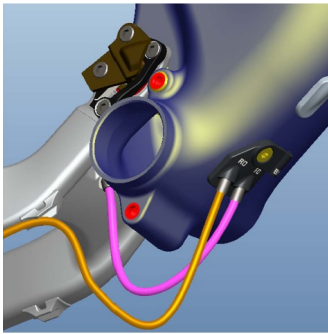

Please make sure to respect the 40mm distance between the cables and the BB (bottom bracket) housing to avoid “ghost-shifting” and/or damages on the shift cables and brake hose.

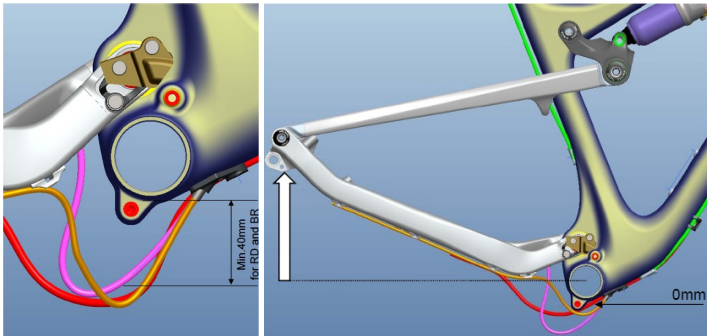

For the rear brake please assemble the cable as shown in the following drawings:

Please keep in mind to have a minimum distance of 40mm between the brake hose and the BB housing as abovementioned!

USE PLASTIC GUIDE TO FIX THE BRAKE CABLE

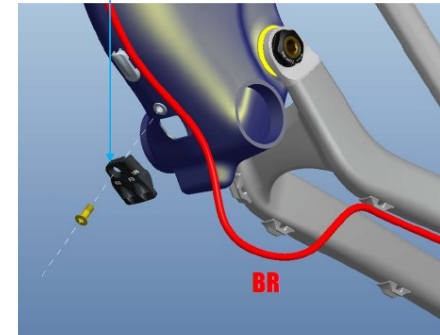

Please fix the brake hose and the remote seatpost cable housing (if applicable) on the frame on the cable mounts with the mount clips by following the routing info as shown below:

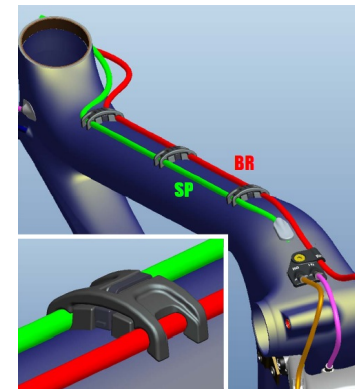

Please secure the clamps with a cable zipper as shown in the drawing below:

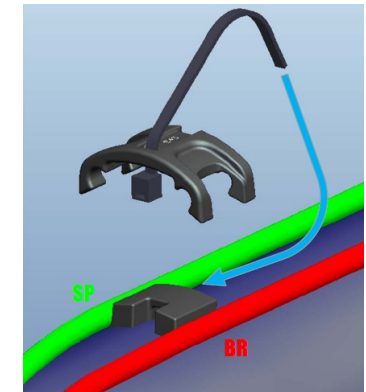

The cable guide can be ordered via the Scott distribution with parts number:

229723	BB cable guide Genius (f. carbon frame)
--------	---

In addition to the derailleur cables and the brake hose you also will see a possibility for an integrated cable routing of the seatpost remote on the carbon version of Genius.

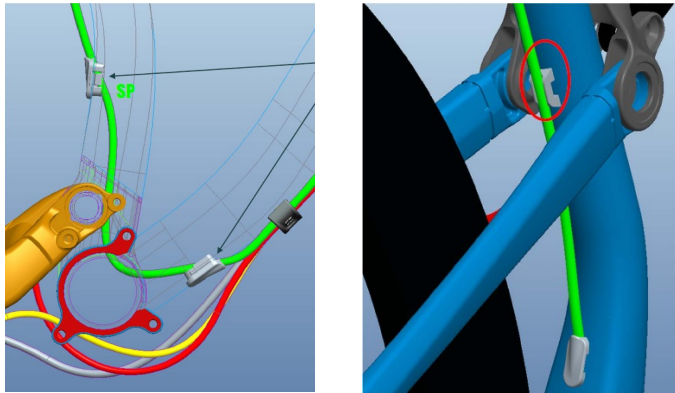

In order to seal the housing ports on the frame you should use the plugs attached to the bike.

**Alloy front frames:**

Please fix the derailleur cable housings, the brake hose and the remote seatpost cable housing (if applicable) on the frame on the cable mounts with the mount clips by following the routing info as shown below:

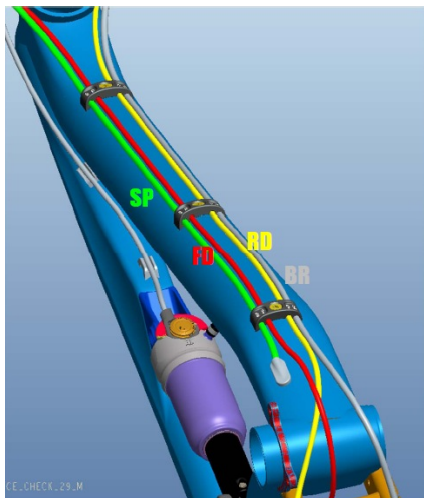

Please tighten the mount bolt with a max. of 4Nm.

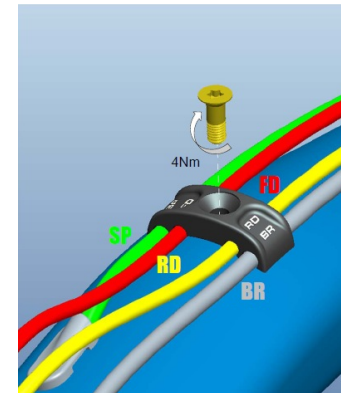

229724	Cabel clamping set Genius alloy 2013 one size
--------	---

Please make sure to respect the 40mm distance between the cables and the BB (bottom bracket) housing to avoid “ghost-shifting” and/or damages on the shift cables and brake hose.

For the rear brake please assemble the cable as shown in the following drawings:

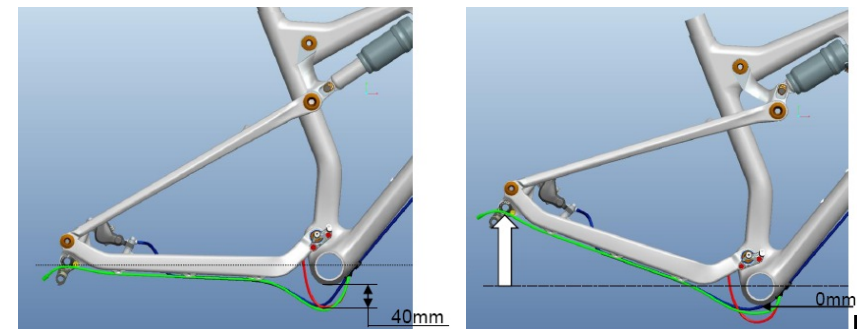

**Important:**

Please make sure to respect the 40mm distance between the brake hose and the BB (bottom bracket).

## REPLACEABLE DROPOUT

On Genius bikes of model year 2013 you can replace the rear derailleur hanger. Depending on the different models you'll find following options:

1. 142mm axle with RWS 142/12

The complete set of RWS 142/12 is available via the Scott distribution with parts number 219574, the right side replaceable RD hanger with 219577.

2. 135mm axle with RWS 135/5

The complete set of RWS 135/5 is available via the Scott distribution with parts number 219572, right side replaceable RD hanger available with 219575

3. Regular 135mm rear axle with QR

The replaceable hanger is available via the Scott distribution with parts number 206473.

In case you want to use another RWS standard Scott also can offer as after-market parts for specific wheelsets following parts via the Scott distribution:

RWS 135/12 parts set: 219574, right side replaceable RD hanger available with 219576

## REAR DISC BRAKE MOUNT

Genius can be used with 3 different disc rotor sizes on the rear brake.

The rear disc brake on Genius is Postmount (PM) Standard on the left seatstay and it is possible to use disc rotors with 180, 185 and 200mm diameter.

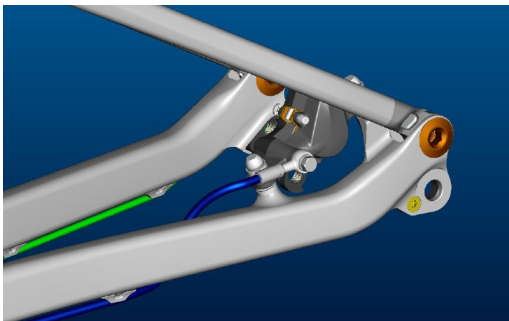

Please note that for the assembly of 185 and 200mm rotors you might need adapters/washers between the PM port on the frame and the brake calliper.

For 185mm rotor diameter you will need 2 red anodized spacers that can be ordered via the Scott distribution with:

219568	Brake mount adaptor spacers 4mm f/185mm
--------	---

For the use of 200mm rotors please use for

SRAM/Avid: "+20mm" adaptor  
Shimano: F180PP2

## ADJUSTMENT OF SEATPOST-HEIGHT

### Important:

The seatpost has to be inserted into the seattube at a minimum of 100mm.

Never use another seatpost diameter than 31.6mm or try to use a shim/reducer between seatpost and frame.

## FRONT FORK SET-UP/CHANGE OF FRONT FORK

For the set up of the front fork please use the fork specific manual attached to the bike.

We recommend using front forks with a travel of 150mm (27.5") and 130mm (29"), as this will not influence the geometry and alter handling of the bike.

For details on the technical length of the recommended forks please refer to the Tech Info Chart before mentioned.

## PIVOT MAINTENANCE

The pivot and bearings on SCOTT Genius are extremely easy to maintain.

An external treatment with a grease spray after every bike wash is all you have to do. We do not recommend heavy grease sprays since these will leave a film on the parts which is difficult to remove. We recommend the same for the chain also.

If you have to change the bearings you can order them included in a service kit at your local SCOTT dealer or buy them with international parts number as shown above in the specs list in a hardware store.

In case of a change of the bearings or of the rear swingarm you should contact your local SCOTT dealer as you need special tools for disassembly and assembly.

# NOTES

---

.....

.....

.....

.....

.....

.....

.....

.....

.....

.....

.....

.....

.....

.....

.....

.....

.....

.....

.....

.....

.....

.....

.....

# WARRANTY

---

Model .....

Year .....

Size .....

Frame Nr. ....

Shock Nr. ....

Date of purchase .....

# WARRANTY

---

SCOTT bikes are made using the most innovative production and quality methods. They are equipped with best components of well known parts suppliers.

Doing so SCOTT warrants its frames and swingarms for five years (subject to compliance with maintenance ranges, see below) and SCOTT forks (provided it is a fork of SCOTT) for two years for defects in material and/or workmanship in case of purchase of completely assembled bikes.

This warranty of 5 years for the frames shall only be granted in case once a year a maintenance service has been effected according to maintenance requirements as set forth in this manual by an authorised SCOTT dealer.

The authorised SCOTT dealer shall confirm the effected annual maintenance service by stamp and signature.

In case such an annual maintenance service has not been effected the warranty of 5 years for the frame shall be reduced to 3 years.

Costs for maintenance and service have to be born by the owner of the SCOTT bike.

On Gambler, Voltage Fr and Volt-X the warranty period is limited to 2 years.

The warranty period starts at the day of purchase. This warranty is limited to the first buyer, what means the first person who uses the bike and only with the use it was made for. Furthermore, this warranty is limited to purchases via authorized SCOTT-dealers

The warranty is solely granted in case of purchase of a completely assembled bike to the explicit exclusion of purchases of not completely assembled bikes.

In case of a warranty claim the decision to repair or to replace the defective part is up to SCOTT. Non defective parts will only be replaced at the guarantee's own expense.

Fair wear and tear is not covered by the warranty.

A complete list of all parts of wear and tear can be found in the next chapter of this manual.

In addition, you will find at the end of this manual a protocol for the handing over of the bike which will remain in copy at the SCOTT dealer after acceptance and signature of the consumer.

It is obligatory to show this protocol of handing over together with the defective part in case of a warranty claim given that it provides evidence of purchase. Otherwise no warranty is granted.

In principle, this warranty is granted worldwide. Claims must be made through an authorized dealer, for information regarding the nearest dealer, write or call this company or the national SCOTT distributor.

Normal wear, accident, neglect, abuse, improper assembly, improper maintenance by other than an authorized dealer or use of parts or devices not consistent with the use originally intended for the bicycle as sold are not covered by this warranty.

Hereby SCOTT grants a voluntarily manufacturer's warranty. Additional entitlements according to national warrant of merchantability are reserved.

For warranty info on the Nude 2 shock please refer to the attached manual of DT Swiss.