

VOLTAGE FR

**SCOTT 2013
BIKE OWNERS
MANUAL**

SCOTT SPORTS SA | 17 RTE DU CROCHET | 1762 GIVISIEZ | SWITZERLAND
© 2011 SCOTT SPORTS SA, ALL RIGHTS RESERVED | SCOTT-SPORTS.COM





The Voltage FR should be adjusted exactly to the current rider for reaching maximum safety and fun while riding. All adjustments should be done at the local Scott dealer or following to this manual.

CONTENT

Voltage FR Concept	P. 004
Geometry Voltage FR	P. 005
Technical Data Voltage FR	P. 006
Adjustable rear Travel	P. 007
Recommended Tools for the Shock Set-Up	P. 009
Set-Up Voltage FR	P. 010
Basic Set-Up of Rebound	P. 011
Set-Up of other shock models	P. 012
IDS Drop Out System	P. 012
Front Fork Set-Up/Change of Front Fork	P. 013
Pivot Maintenance	P. 013
Warranty	P. 014

VOLTAGE FR CONCEPT

Voltage FR is the result of 3 years of research and development searching for one of the most versatile and durable FR and slopestyle bikes available on the market, but still easy in set-up and maintenance.

Scott's focus was not only on lightweight but also on a durable and sturdy frame with an optimized kinematics of the rear swingarm.

Voltage FR was designed for riders looking for a dual suspended FR bike or a slopestyle bike offering rear wheel travel between 135 and 180 mm.

The Voltage FR Concept is based on a new low-leverage ratio multi-pivot technology.

In combination with the linear coil-over shock characteristics the kinematics guarantees a progressive suspension, adapted to smooth riding (beginning of travel) as well as extreme jumps (end of travel).

In addition with the help of different shock mounts the kinematics of the rear end can also be adjusted to the use of air-shox.

GEOMETRY VOLTAGE FR

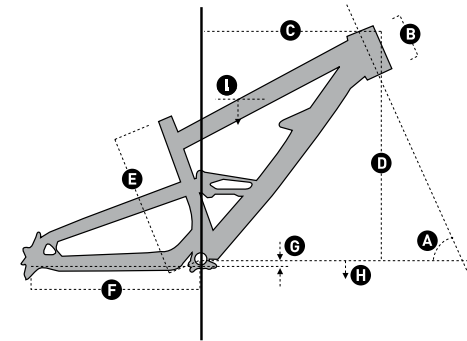

	A	B	C	D	E	F	G	H	I	Wheel base	Stem length
Size	Head angle	Head tube length	Reach	Stack	BB center to top of seat tube	Chainstay length	BB offset	BB height	Standover height	mm inches	mm
	°	mm inches	mm inches	mm inches	mm inches	mm inches	mm inches	mm inches	mm inches	mm inches	mm

VOLTAGE FR with 160mm Fork

short	66.0°	118 4.6	394 15.5	567 22.3	402 15.8	425 16.7	13 0.5	358 14.1	763 30.0	1131 44.5	40
long	66.0°	118 4.6	419 16.5	567 22.3	402 15.8	425 16.7	13 0.5	358 14.1	763 30.0	1150 45.3	40

VOLTAGE FR with 180mm Fork

short	65.0°	118 4.6	383 15.1	575 22.6	402 15.8	425 16.7	13 0.5	366 14.4	777 30.6	1135 44.7	40
long	65.0°	118 4.6	408 16.1	575 22.6	402 15.8	425 16.7	13 0.5	366 14.4	777 30.6	1155 45.5	40

TECHNICAL DATA VOLTAGE FR

Travel	Frame only:	135 / 150
	FR 10 / 20:	165 / 180
	FR 30:	150 / 170
Suspension Ratio	241 / 76mm shock:	2.1 / 2.3
	222 / 70mm shock:	2.2 / 2.4
	215 / 63.5 shock:	2.1 / 2.3
Piston stroke	76 / 70 / 63.5mm	
Shock length (Eye to Eye)	241 / 222 / 215mm, please make sure to use matching shock mount!	
Hardware Mainframe	22.2mm x 8mm	
Hardware Swingarm	22.2mm x 8mm	
Seatpost diameter	31.6mm	
Headset	1.5"	
Fork travel	160 - 200mm	
Fork length	525 - 571mm	
BB housing	73mm	
Chainguide system	ISCG / ISCG05 tab	
Rear Hub Width	135mm	
Bearings	2 x 61901 (24 x 12 x T6)	
	6 x 61902 (28 x 15 x T7)	
Max tire width	64mm	
Chainring size	Single speed, 34 to max. 38T	

ADJUSTABLE REAR TRAVEL

Depending on the different models of Voltage FR you'll find different shock mounts that will help to match the different shox (different eye-to-eye length) to the frames without changing seat/headtube-angles or riding position on the bike.

In case you want to change the originally mounted shock model on the bike/frame set to another model, please make sure that you always use the matching shock mount.

Those shock mounts are available as a set via your local Scott dealer.

SHOCKMOUNT 215

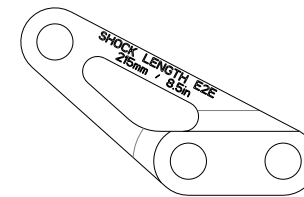

SHOCKMOUNT 222

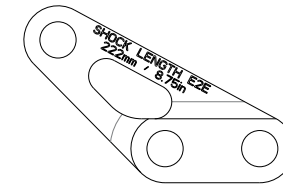

SHOCKMOUNT 241

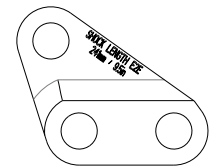

Shockmount	Shocklength E2E	A: Short travel	B: Long travel
215	215mm / 8.5in	140mm / 5.3in	150mm / 5.9in
222	222mm / 8.75in	150mm / 5.9in	170mm / 6.7in
241	241mm / 9.5in	160mm / 6.3in	180mm / 7.0in

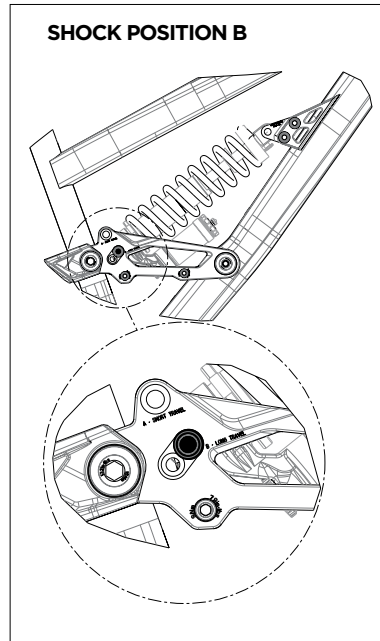
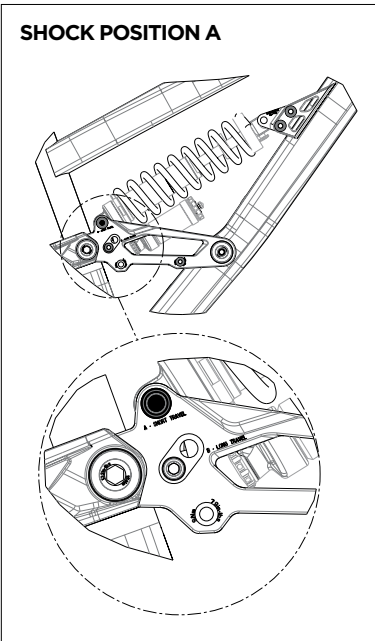

Important!

After a dismantlement of the rear shock, both fixing bolts should be tightened with a tightening torque of 35Nm/308in-lbs.

If this is not done correctly the rear shock can be damaged.

In addition we strongly recommend using a tightening torque key with a 6mm allen key insert

RECOMMENDED TOOLS FOR THE SET-UP

Please read this manual and the manual of the rear shock manufacturer carefully before you start the set-up procedure.

In addition we strongly recommend using a tightening torque key with a 6mm allen key insert.

To simplify the check of the SAG (= negative travel) of the rear shock please use the "SAG-Boy" printed as a color-beam on the cover of this manual.

SET-UP VOLTAGE FR

The Set-Up of the rear shock can be easily done within a few minutes.

Please take this time to avoid dangerous riding performance and to get the best out of your Voltage FR.

Please make sure that the coil spring on the shock matches to your riding weight (including your riding gear).

We recommend following coil springs:

Weight (kg)	Recommended coil springs
50 - 60	200 x 3.25
60 - 70	250 x 3.25
70 - 80	300 x 3.25
80 - 90	350 x 3.25

The eye-to-eye distance between the shock bolts should be in basic set up with 40% SAG.

Shocklength	E2E with 40% SAG
241mm	211mm
222mm	194mm
215mm	189mm

For fine tuning the SAG and the corresponding eye-to-eye distance of the shock bolts you can tighten or release the pretension of the coil spring but please respect the maximum and minimum spring indications of the shock manufacturer.

The eye-to-eye distance between the shock bolts should be in basic set up with 40% SAG. This length is also indicated on the cover of this manual by the colored beam of the SAG-Boy.

For further details on the shock set-up please follow the indications of the rear shock manufacturer attached to this bike.

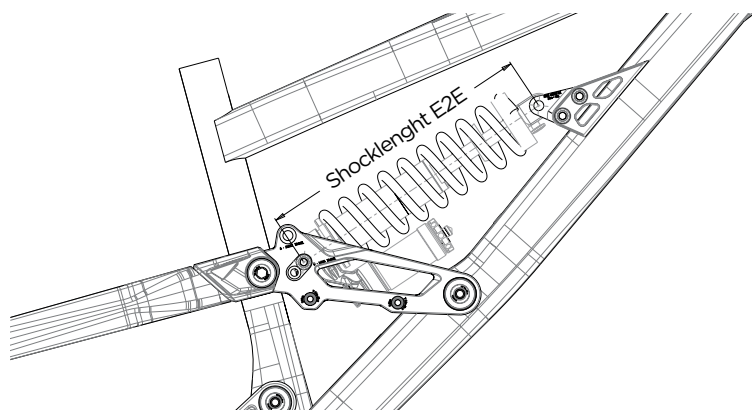

BASIC SET-UP OF REBOUND

“Rebound” describes the speed the shock comes back to its original length after absorbing an obstacle.

By using the red rebound screw you can adjust the rebound step by step.

Please refer to the following instruction:

Ride your bike off a pavement (remain in the saddle) and check how many times it bounces.

- If it bounces 1-2 times, the set up is good.
- If it bounces more than 3 times the rebound is too fast. Turn the screw 1-2 “clicks” clockwise.
- If it does not bounce the rebound is too slow. Turn the screw 1-2 “clicks” counter clockwise.

Important:

After a dismantlement of the rear shock, both fixing bolts should be tightened with a tightening torque of 35Nm/308in-lbs.

If this is not done correctly the rear shock can be damaged.

Important!

Note that you have to mount the rear shock always as shown underneath.

Mounting the rear shock in a different position can cause severe damages to the frame, the linkage levers and the rear shock.

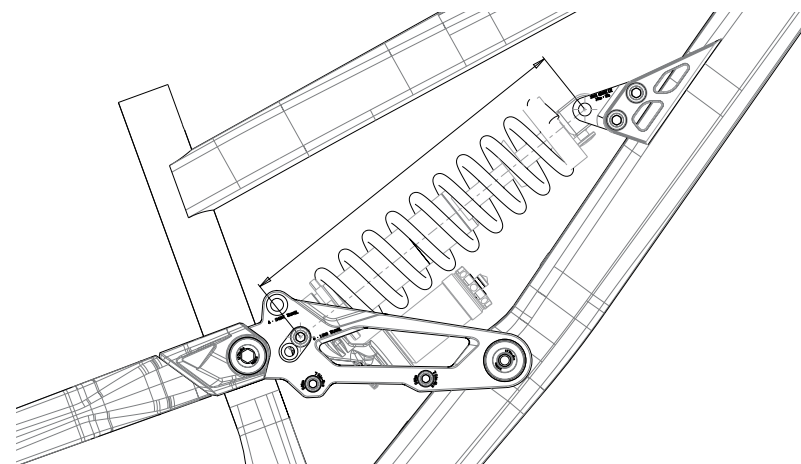

SET-UP OF OTHER SHOCK MODELS

Scott strongly recommends using only the originally specified shock with the Voltage FR bike, as we have chosen carefully both parts for a perfect matching combination.

If you want to use a different rear shock model than the one originally on the bike, please make sure that the shock will not in any position hit the frame and cause a damage to the frame.

Please follow the instruction below:

Please make sure that the rear shock or its accessory parts do not touch the frame when mounting or suspending.

For doing so release the air/remove the coil, install the shock and compress the shock completely.

If the shock touches the frame while doing so, do not use this shock in order to avoid damage to frame, swingarm or shock

IDS DROP OUT SYSTEM

The Voltage FR offers the possibility not only to change drop out hanger in case of damage, you also can choose between different several different drop outs of the Scott IDS (Interchangeable Drop-Out System):

Inline you will find on Voltage FR 10/20 a 12mm through axle system, on FR 30 a standard axle system.

In addition Scott offers following options:

- IDS 12mm short (10mm reduced wheelbase)
- IDS 12mm long (10mm prolonged wheelbase)
- IDS Maxle for SRAM Maxle System

Please contact your local Scott dealer for supply of those parts in case you want to re-fit your bike with one of those versions.

FRONT FORK SET-UP/ CHANGE OF FRONT FORK

For the set up of the front fork please use the fork specific manual attached to the bike.

We recommend using front forks with distance of 525mm to 571mm between mid of axle to top of crown, as this will not influence the geometry and alter handling of the bike.

PIVOT MAINTENANCE

The pivots and bearings on SCOTT Voltage FR are extremely easy to maintain.

An external treatment with a grease spray after every bike wash is all you have to do. We do not recommend heavy grease sprays since these will leave a film on the parts which is difficult to remove. We recommend the same for the chain also.

If you have to change the bearings you can order them included in a service kit at your local SCOTT dealer or buy them with international parts number as shown above in the specs list in a hardware store.

In case of a change of the bearings or of the rear swingarm you should contact your local SCOTT dealer as you need a special tool kit for disassembly and assembly.

WARRANTY

Model

Year

Size

Frame

Date of purchase

WARRANTY

SCOTT bikes are made using the most innovative production and quality methods. They are equipped with best components of well known parts suppliers.

Doing so SCOTT warrants its frames and swingarms for five years (subject to compliance with maintenance ranges, see below) and SCOTT forks (provided it is a fork of SCOTT) for two years for defects in material and/or workmanship in case of purchase of completely assembled bikes.

This warranty of 5 years for the frames shall only be granted in case once a year a maintenance service has been effected according to maintenance requirements as set forth in this manual by an authorised SCOTT dealer.

The authorised SCOTT dealer shall confirm the effected annual maintenance service by stamp and signature.

In case such an annual maintenance service has not been effected the warranty of 5 years for the frame shall be reduced to 3 years.

Costs for maintenance and service have to be born by the owner of the SCOTT bike.

On Gambler, Voltage Fr and Volt-X the warranty period is limited to 2 years.

The warranty period starts at the day of purchase. This warranty is limited to the first buyer, what means the first person who uses the bike and only with the use it was made for. Furthermore, this warranty is limited to purchases via authorized SCOTT-dealers

The warranty is solely granted in case of purchase of a completely assembled bike to the explicit exclusion of purchases of not completely assembled bikes.

In case of a warranty claim the decision to repair or to replace the defective part is up to SCOTT. Non defective parts will only be replaced at the guarantee's own expense.

Fair wear and tear is not covered by the warranty.

A complete list of all parts of wear and tear can be found in the next chapter of this manual.

In addition, you will find at the end of this manual a protocol for the handing over of the bike which will remain in copy at the SCOTT dealer after acceptance and signature of the consumer.

It is obligatory to show this protocol of handing over together with the defective part in case of a warranty claim given that it provides evidence of purchase. Otherwise no warranty is granted.

In principle, this warranty is granted worldwide. Claims must be made through an authorized dealer, for information regarding the nearest dealer, write or call this company or the national SCOTT distributor.

Normal wear, accident, neglect, abuse, improper assembly, improper maintenance by other than an authorized dealer or use of parts or devices not consistent with the use originally intended for the bicycle as sold are not covered by this warranty.

Hereby SCOTT grants a voluntarily manufacturer's warranty. Additional entitlements according to national warrant of merchantability are reserved.