

Spark

**SCOTT 2013
BIKE OWNERS
MANUAL**

SCOTT SPORTS SA | 17 RTE DU CROCHET | 1762 GIVISIEZ | SWITZERLAND
© 2011 SCOTT SPORTS SA, ALL RIGHTS RESERVED | SCOTT-SPORTS.COM





The Spark should be adjusted exactly to the current rider for reaching maximum safety and fun while riding.

All adjustments should be done at the local Scott dealer or following to this manual.

In order to avoid technical problems or any harm please contact in case of doubts your authorized Scott dealer.

CONTENT

Spark Concept	P. 004
Geometry Spark 26" and 29"	P. 005
Technical Data Spark 26"	P. 006
Technical Data Spark 29"	P. 007
TC Shock Technology/Twinloc Levers	P. 008
Nude 2 Shock and Twinloc Remote Control Lever	P. 015
Basic Set-Up of the Twinloc Remote Control	P. 016
Recommended Tools for the Shock Set-Up	P. 018
Set-Up Spark with Scott Nude 2 TC Shock	P. 019
Set-Up of other shock models	P. 023
Headset Options	P. 024
Bottom Bracket on Spark	P. 025
Adjustable BB Height	P. 026
Front Derailleur Mounting Details	P. 027
Spark Cable Routing	P. 028
Adjustment of Seatpost-Height	P. 034
Replaceable Drop Out Systems	P. 034
Rear Disc Brake Mount	P. 036
Front Fork Set-Up/Change of Front Fork	P. 037
Pivot Maintenance	P. 037
Warranty	P. 038

SPARK CONCEPT

The new Spark is the result of 2 years of research and development for one of the lightest mountain bike frame set available on the market, hitting the scale at below 1800 grams (4 lbs) including the frame, Scott Nude 2 shock and the unique TWINLOC remote control.

Scott's focus was not only on lightweight but also on a durable and stiff frame with an innovative suspension technology in combination with an optimized kinematics of the rear swingarm.

The combination of an optimized kinematics with an extraordinary suspension technology closes the gap between superlight hardtail bikes (e.g. Scott Scale) and the new generation of marathon bikes (e.g. Scott Genius).

Spark was designed for riders looking for a dual suspended race and marathon bike offering a maximum rear wheel travel of 120mm (26")/100mm (29").

Scott does not see frame and rear shock as single components which are assembled together on a bike, but as a concept with all these components working together and offering an outrageous function by matching perfectly.

The Spark Concept is based on a multi-pivot technology.

The damping performance was improved in comparison to the already famous "old" Spark, and with reworking also the kinematics we were able to reach a better progression in the end of the stroke/travel of the swingarm.

The Scott system, named TC (Traction Control) will allow you to reduce by remote control the rear wheel travel from 120 (26")/100 (29")mm to 85 (26")/70(29")mm including a more progressive spring rate but still offering a supple break away.

No power will be lost and an optimum power transfer is guaranteed as the swingarm, in contrary to locked or automatic-locking systems, can follow the trail surface and will offer perfect traction and higher speed while standing on the pedals.

GEOMETRY SPARK 26" AND 29"

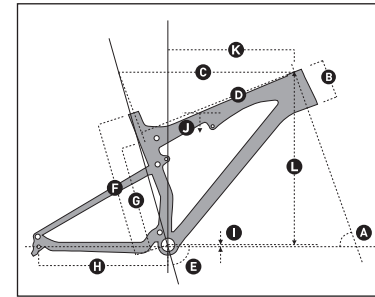

SPARK 26"

	S HIGH BB setting	S LOW BB setting	M HIGH BB setting	M LOW BB setting	L HIGH BB setting	L LOW BB setting	XL HIGH BB setting	XL LOW BB setting
A HEAD TUBE ANGLE	68.7°	68.0°	68.7°	68.0°	68.7°	68.0°	68.7°	68.0°
B HEADTUBE LENGTH	110mm 4.3in	110mm 4.3in	120mm 4.7in	120mm 4.7in	140mm 5.5in	140mm 5.5in	160mm 6.3in	160mm 6.3in
C TOP TUBE LENGTH HORIZONTAL	553mm 21.8in	555mm 21.9in	589mm 23.2in	590mm 23.2in	618mm 24.3in	620mm 24.4in	648mm 25.5in	650mm 25.6in
D TOP TUBE LENGTH ACTUAL	509mm 20.0in	509mm 20.0in	540mm 21.5in	540mm 21.5in	570mm 22.4in	570mm 22.4in	602mm 23.7in	602mm 23.7in
E SEAT TUBE ANGLE	74.2°	73.5°	74.2°	73.5°	74.2°	73.5°	74.2°	73.5°
F BB CENTER TO TOP OF SEAT TUBE	400mm 15.7in	400mm 15.7in	450mm 17.7in	450mm 17.7in	490mm 19.3in	490mm 19.3in	540mm 21.3in	540mm 21.3in
G BB CENTER TO TOP TUBE CENTER	431mm 13.0in	431mm 13.0in	437mm 13.0in	437mm 13.0in	395mm 15.6in	395mm 15.6in	435mm 17.1in	435mm 17.1in
H CHAINSTAY LENGTH	420mm 16.5in	420mm 16.5in	420mm 16.5in	420mm 16.5in	420mm 16.5in	420mm 16.5in	420mm 16.5in	420mm 16.5in
I BB OFFSET	2mm 0.1in	-8mm -0.3in	2mm 0.1in	-8mm -0.3in	2mm 0.1in	-8mm -0.3in	2mm 0.1in	-8mm -0.3in
J BB HEIGHT	342mm 13.5in	332mm 13.1in	342mm 13.5in	332mm 13.1in	342mm 13.5in	332mm 13.1in	342mm 13.5in	332mm 13.1in
K REACH	397mm 15.6in	391mm 15.4in	429mm 16.9in	423mm 16.7in	453mm 17.8in	448mm 17.6in	478mm 18.8in	473mm 18.6in
L STACK	552mm 21.7in	556mm 21.9in	561mm 22.1in	565mm 22.2in	579mm 22.8in	583mm 23.0in	598mm 23.5in	602mm 23.7in
STEM LENGTH	70mm	70mm	80mm	80mm	90mm	90mm	100mm	100mm

SPARK 29"

	S HIGH BB setting	S LOW BB setting	M HIGH BB setting	M LOW BB setting	L HIGH BB setting	L LOW BB setting	XL HIGH BB setting	XL LOW BB setting
A HEAD TUBE ANGLE	70.1°	69.5°	70.1°	69.5°	70.1°	69.5°	70.1°	69.5°
B HEADTUBE LENGTH	105mm 4.1in	105mm 4.1in	105mm 4.1in	105mm 4.1in	115mm 4.5in	115mm 4.5in	125mm 4.9in	125mm 4.9in
C TOP TUBE LENGTH HORIZONTAL	568mm 22.4in	570mm 22.4in	598mm 23.5in	600mm 23.6in	628mm 24.7in	630mm 24.8in	649mm 25.6in	650mm 25.6in
D TOP TUBE LENGTH ACTUAL	518mm 20.4in	518mm 20.4in	539mm 21.2in	539mm 21.2in	568mm 22.3in	568mm 22.3in	588mm 23.1in	588mm 23.1in
E SEAT TUBE ANGLE	73.1°	72.5°	73.1°	72.5°	73.1°	72.5°	73.1°	72.5°
F BB CENTER TO TOP OF SEAT TUBE	400mm 15.7in	400mm 15.7in	440mm 17.5in	440mm 17.5in	481mm 18.9in	481mm 18.9in	541mm 21.3in	541mm 21.3in
G BB CENTER TO TOP TUBE CENTER	335mm 13.2in	335mm 13.2in	350mm 13.8in	350mm 13.8in	403mm 15.9in	403mm 15.9in	448mm 17.6in	448mm 17.6in
H CHAINSTAY LENGTH	448mm 17.6in	448mm 17.6in	448mm 17.6in	448mm 17.6in	448mm 17.6in	448mm 17.6in	448mm 17.6in	448mm 17.6in
I BB OFFSET	-4mm -1.6in	-4mm -1.6in	-4mm -1.6in	-4mm -1.6in	-4mm -1.6in	-4mm -1.6in	-4mm -1.6in	-4mm -1.6in
J BB HEIGHT	324mm 12.8in	317mm 12.5in	324mm 12.8in	317mm 12.5in	324mm 12.8in	317mm 12.5in	324mm 12.8in	317mm 12.5in
K REACH	386mm 15.2in	379mm 14.9in	416mm 16.4in	409mm 16.1in	442mm 17.4in	436mm 17.2in	456mm 18.0in	453mm 17.8in
L STACK	602mm 23.7in	606mm 23.9in	602mm 23.7in	606mm 23.9in	611mm 24.1in	615mm 24.2in	623mm 24.5in	625mm 24.6in
STEM LENGTH	70mm	70mm	80mm	80mm	90mm	90mm	100mm	100mm

TECHNICAL DATA SPARK 26"

Travel	120/85/0mm
Suspension Ratio	2.4
Piston stroke	50mm
Shock length (Eye to Eye)	190mm
Hardware Mainframe	22.2mm x 6mm
Hardware Swingarm	22.2mm x 6mm
Seatpost diameter	31.6mm
Headset	semi integr. for tapered 1 1/8-1.5 (44.0/54.9mm inner diameter of frame) or with 1 1/8 straight (44.0mm)
Fork travel	120mm
Fork length	490mm
BB housing	BB PF 92 carbon / 73mm alloy
Front derailleur	Shimano E-Type / SRAM S3 direct mount
Bearings	2 x IGUS, 6 x 6802 (24x15x5)

TECHNICAL DATA SPARK 29"

Travel	100/70/0mm
Suspension Ratio	2.63
Piston stroke	38mm
Shock length (Eye to Eye)	165mm
Hardware Mainframe	22.2mm x 6mm
Hardware Swingarm	22.2mm x 6mm
Seatpost diameter	31.6mm
Headset	semi integr. for tapered 1 1/8-1.5 (44.0/54.9mm inner diameter of frame) or with 1 1/8 straight (44.0mm)
Fork travel	100mm
Fork length	503mm
BB housing	BB PF 92 carbon / 73mm alloy
Front derailleur	Shimano E-Type / SRAM S3 direct mount
Bearings	2 x IGUS, 6 x 6802 (24x15x5)

TC SHOCK TECHNOLOGY/TWINLOC LEVER

The heart of the TC-System is the new developed Scott Nude 2 Shock made by DT Swiss, offering three functions which make this system possible.

The TWINLOC remote control lever is the evolution of the already outstanding TRACLOC system of Scott.

While TRACLOC allowed only the change on the Scott TC rear shocks between the Scott patented Lock-out, traction and full-mode on the fly from the handlebar, the TWINLOC allows also the remote control of the front fork to shift between lock-out and open mode at the same time when you change the modes on the Scott rear shox.

In combination with SRAM/RockShox DNA 3 forks it is also possible to have a traction mode on the fork. This is made exclusively for Scott.

The 3 modes on the lever and suspension units are:

- **ALL TRAVEL MODE:** Full travel rear, full travel front
- **TRACTION MODE:** Traction mode rear, full travel front (with SRAM/RockShox DNA 3 fork: traction mode)
- **LOCK-OUT MODE:** Lock-out rear, lock-out front

Therefore Scott offers 3 different TWINLOC/Nude 2 levers with following fork/rear shock combinations:

- Nude 2 with SRAM DNA 3 fork (Scott Article number: 223298)
- Nude 2 with adapters for SRAM /RockShox fork and FOX fork/DT Swiss fork (Scott Article number: 216351)
- DT M210 with adapters for SRAM /RockShox fork and FOX fork/DT Swiss fork (Scott Article number: 216352)

Please note that the DT Swiss M210 rear shock does not offer a traction mode, but only lock-out and full-mode.

IMPORTANT:

You can only assemble the TWINLOC remote lever in "left side upward position" on the handlebar.

You have 3 positions on the TWINLOC remote lever.

- **most forward position:** ALL TRAVEL MODE
- **middle position:** TRACTION MODE
- **most backward position:** LOCK-OUT MODE

By using the TWINLOC remote lever you can chose following functions:

1. ALL TRAVEL MODE: full travel of 120/100mm (26"/29")
2. TRACTION MODE: by reducing the internal chamber volume inside the shock the travel of the shock will be reduced to around 60% (approx. 85/70mm) the characteristic of the air spring gets harder. This results in climbing without "bobbing" and offers still optimum traction of the rear wheel.
3. LOCK OUT MODE: the shock is locked; climbing on asphalt roads is now possible without any power loss. Simultaneous a blow-off-system prevents the shock being damaged in case the rider did not open the system while crossing obstacles.

You will find the following positions on the remote lever:

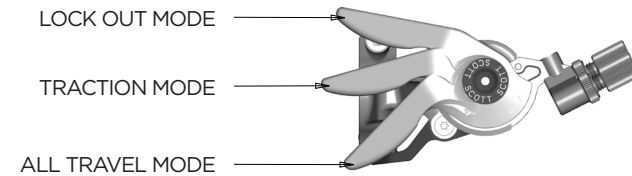

For the assembly of the remote control of the front fork lock-out 3 different cable systems are existing.

The different roll for the pull of the fork remote cable can be changed within few minutes to adapt the lever to your fork model/brand.

You will see on the downside of the roll the indication of the fork brand or the fork model.

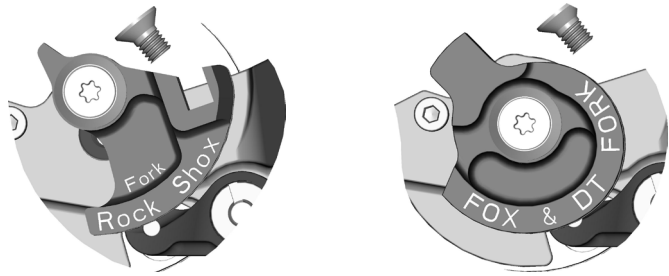

For RockShox forks Scott offers 2 different levers.

1. For regular 2 position fork in lockout and full-mode with a red colored roll with Scott article number: 216351
2. For forks with DNA mode made exclusively for Scott with a traction mode option also on the fork with an blue colored roll with a "DNA3" logo on the roll with Scott article number: 223298

The remote cable assembly is the same on both versions, please refer to the description shown below after the explanation of the change of the rolls between different fork brands.

Please kindly note that the cable roll of a DNA3 fork-lever is not interchangeable with the regular rolls of 2 step forks. You need to use another lever!

To change the rolls to match another fork brand pls follow the drawings below:

ROLL FORK UNMOUNTING

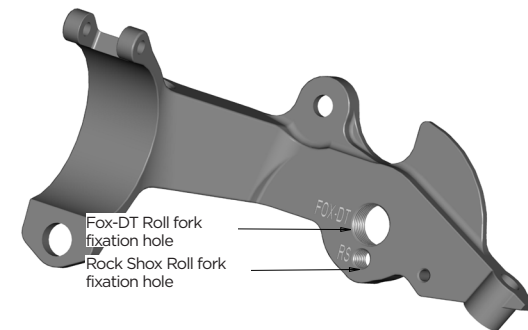
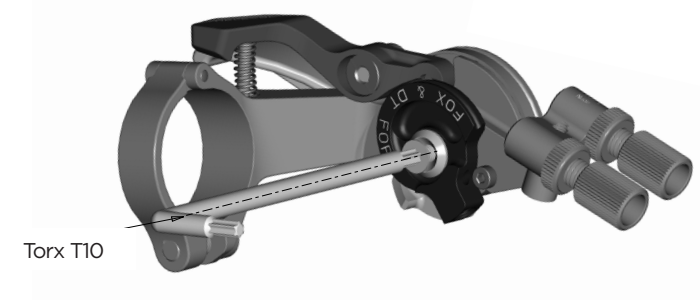

ROLL FORK MOUNTING

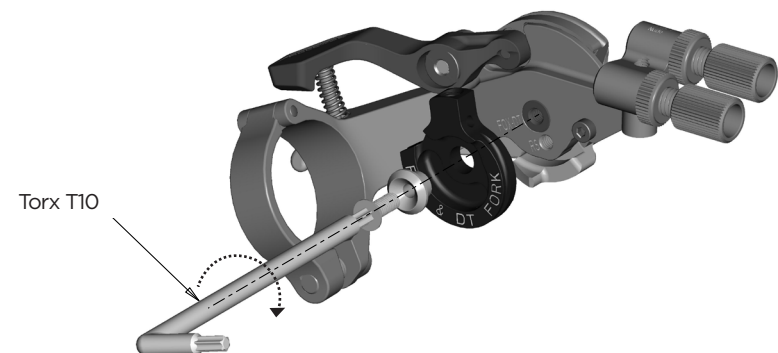

ASSEMBLY OF THE REMOTE CABLE

SRAM/ROCKSHOX FORKS:

IMPORTANT:

Please make sure the lockout of SRAM/RockShox fork is activated after transport correctly. Therefore please compress fork 5-10 times before following the manual on remote cable installation and adjustment.

The lever should show on the downside of the cable roll follow indication:

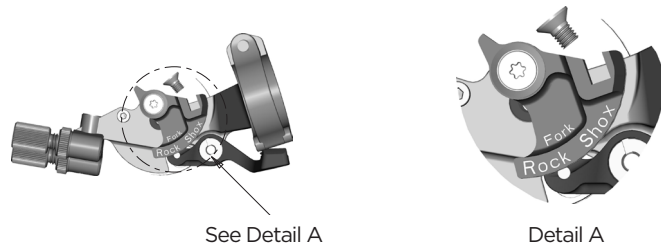

To assemble the cable please bring the lever into the All Travel Mode, push the cable into the lever-eyelet as shown on drawing below, push it through the pre-cut cable housing and fix it at the assembly unit on top of the right side of the fork crown.

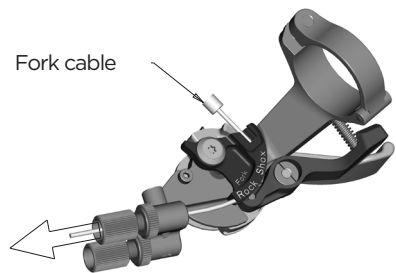

Fix the cable with the 2mm allen screw on the barrel adjuster on the fork crown with a tightening torque of 0.9Nm/ 8lb/in, cut the cable and secure it with a cable end-cap. Please refer for this action also to the manual of SRAM/RockShox attached to the bike.

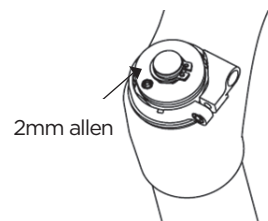

FOX-DT SWISS FORKS

IMPORTANT:

Please make sure the lockout of FOX/DT fork is activated after transport correctly. Therefore please compress fork 5-10 times before following the manual on remote cable installation and adjustment.

The lever should show on the downside of the cable roll follow indication:

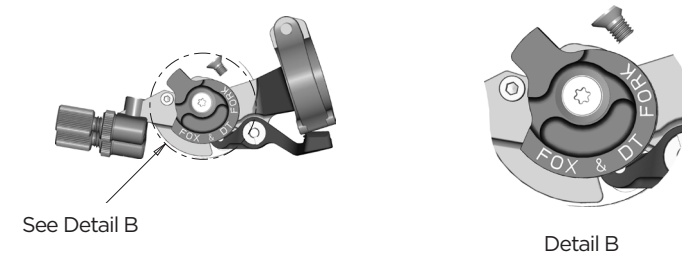

To assemble the cable please bring the lever into the Full (Travel) Mode



push the pre-cut cable through the pre-cut cable housing into the lever as shown on drawing below

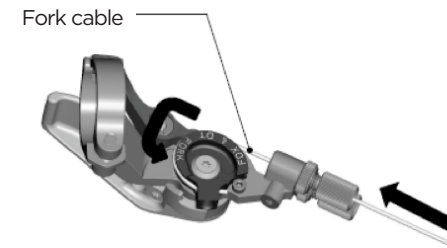

and secure the cable by fixing the 2mm allen screw with a tightening torque of 0.9Nm/ 8lb/in as shown on the drawing below on the roll.

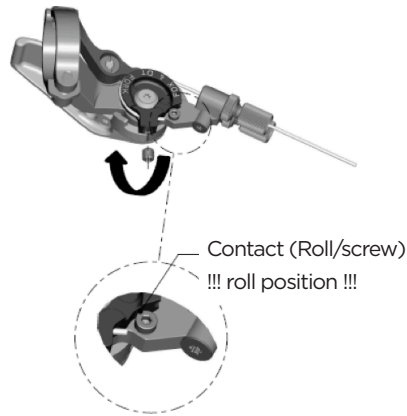

Cut the cable 5mm behind the roll and secure it with a cable end-cap.

Please refer for this action also to the manual of FOX or DT Swiss attached to the bike. In case you need to remove the remote cable completely from the forks of FOX or DT Swiss please follow the instructions of the related fork manuals of the fork manufacturers or contact a fork service center / your local dealer to do so.

TIP:

To check for accurate cable tension, please try to move the plastic end cap of the cable housing at the barrel adjuster on the remote lever. There should be “no-play” between cap and barrel adjuster. In case of “play” please turn the barrel adjuster clockwise until “no-play”.

NUDE 2 SHOCK AND TWINLOC REMOTE CONTROL LEVER

In the drawing of the shock and remote lever, shown below, you will see the parts indicated with numbers which will be used in the manual for the adjustment and set-up.

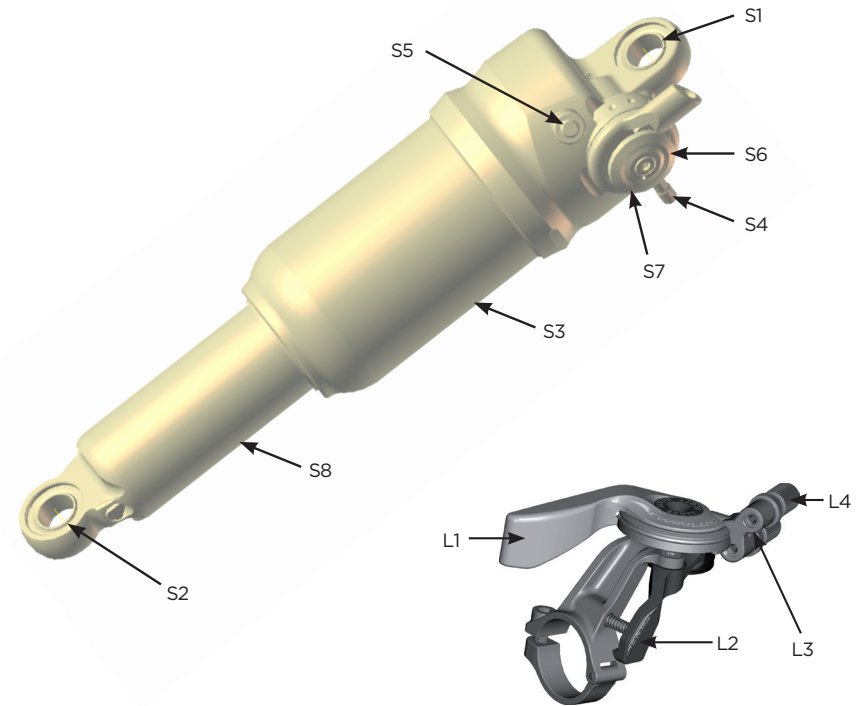

S1	Front eyelet/ Shock Bolt	L1	Remote Lever
S2	Rear eyelet/ Shock Bolt	L2	Release Button
S3	Shock Housing	L3	Remote Control Cables
S4	Rebound-Adjuster Knob	L4	Cable Tension Screw Fork Remote
S5	Positive Chamber Valve	L5	Cable Tension Screw Shock Remote
S6	Remote Control Wheel		
S7	Cable Fixing Screw (hidden behind remote wheel)		
S8	Shock Piston		
S9	SAG Indicator (o-ring on piston)		

BASIC SET-UP OF THE TWINLOC REMOTE CONTROL

NUDE 2 SHOCK:

To ensure perfect function of the Nude 2 TC shock it is very important to follow the steps shown below exactly.

On Spark Carbon frames you will find an internal cable routing.

Push the inner cable first through the remote lever in the upper cable routing of the lever and then through the cable housing as shown below inside the toptube.

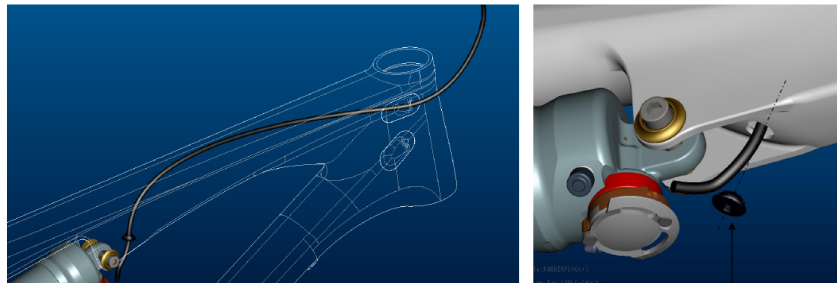

Slide the rubber plug on the outer-cable

On alloy frames a regular outside cable routing, the outer cable housing is fixed on cable mount ports with cable zippers.

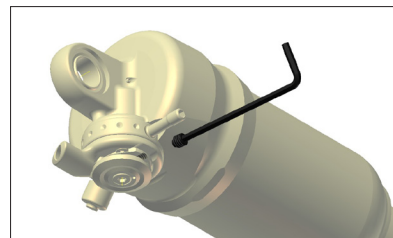

- 1 Loosen the cable fixing screw (S7) by turning it counter clockwise with a 2mm allen key.

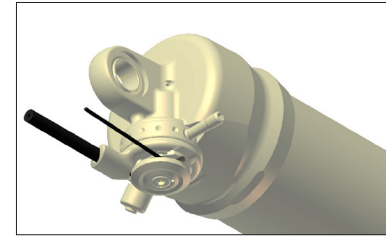

- 2 Insert a new cable via lever hole and cable housing and push it into the shock as shown around the remote wheel (S6)

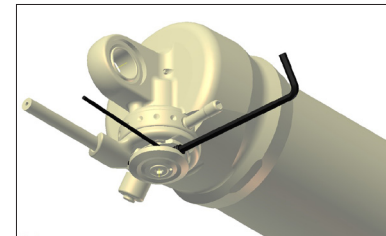

- 3 Tighten the cable and fix the cablefixing screw (S7) by turning it clockwise with a 2mm allen key and a max. Tightening torque of 1.6Nm.

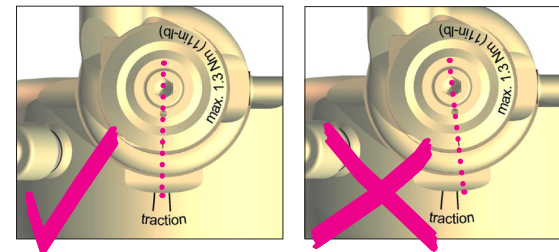

- 4 Check

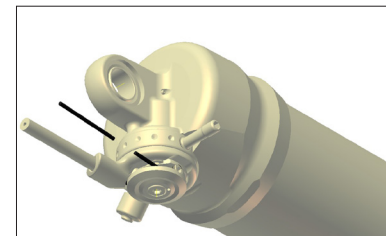

- 5 Cut the cable approx. 20mm away from the remote wheel and push a cable end-cap on the cable until it touches the end of the cable. Fix it by squeezing it with pliers.

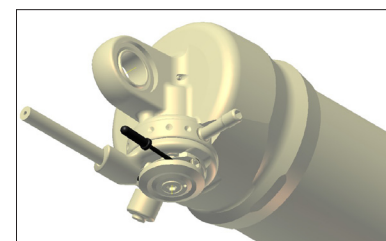

- 6 Push a cable end-cap on the cable until it touches the end of the cable. Fix it by squeezing it with pliers.

DT M210 SHOCK:

Please follow the details shown in the manuals of DT Swiss attached to this bike.
Basically it is very similar to the abovementioned assembly of the Nude 2.

RECOMMENDED TOOLS FOR THE SHOCK SET-UP

For the set-up of the shock we recommend to use a shock pump with a scale up to 20 bars/300 psi with a special air valve connector preventing from air getting away while removing the pump from the shock valve, this will result in an exact air pressure.

Please note that air will flow into the hose and indicator when counterchecking the air pressure, so you have to set up again the recommended pressure after this action.

Make sure to balance at least this air loss when you make a check of the air pressure of the shock. Pls also note that the indicators of shock pumps have a tolerance of max. 10%

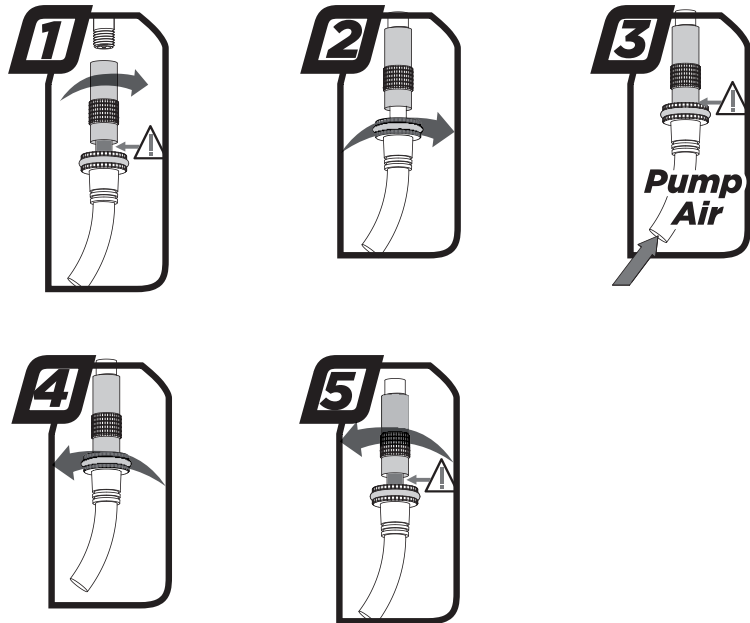

SET-UP SPARK WITH NUDE 2 SHOCK

The Set-Up of the Scott Nude TC Shock can be easy done within a few minutes.

IMPORTANT:

For all adjustments of the air spring the remote lever has to be in position "all travel"

To adjust the air pressure of the air chamber of the Scott Nude 2 Shock please refer to the following instruction:

1. Remove the valve cap of the valve (S5) located on the shock housing (S3).
2. Mount the shock pump with its adaptor on the valve
3. Pls take into account that it takes some air pressure from inside the shock to drive the indicator on the pump. Make sure to balance at least this air loss when you make a check of the air pressure of the shock. Pls also note that the indicators of shock pumps have a tolerance of max. 10%
4. Pump the recommended pressure into the shock. On the shock you will find a decal showing the recommended air pressure of the positive chamber according to the rider's weight.
5. When you reached the needed pressure remove the pump and put the valve cap on the valve

RECOMMENDED AIR PRESSURE

NUDE2 SPARK 26, 120MM TRAVEL

Riders Weight		Air Pressure	
KG	LBS	BAR	PSI
45	99	3.9	57
50	110	4.4	64
55	121	4.9	71
60	132	5.4	79
65	143	5.9	86
70	154	6.4	93
75	165	7.0	101
80	176	7.5	109
85	187	8.0	116
90	198	8.6	124
95	209	9.1	132
100	220	9.7	140
105	231	10.2	148
110	242	10.8	156

NUDE2 SPARK 29, 100MM TRAVEL

Riders Weight		Air Pressure	
KG	LBS	BAR	PSI
45	99	4.5	65
50	110	5.0	72
55	121	5.5	80
60	132	6.1	89
65	143	6.7	97
70	154	7.3	106
75	165	7.9	114
80	176	8.5	123
85	187	9.1	132
90	198	9.8	142
95	209	10.4	151
100	220	11.1	160
105	231	11.7	170
110	242	12.4	180

SAG

The SAG should be 10mm on the shock piston.

To check the adjustment, please follow as shown below:

1. Sit on the bike, put your feet on the pedal
2. Put your feet back on the ground and stand over the bike without bouncing the bike during this action
3. Check if the o-ring (S9) on the shock piston (S8) has a distance of 10mm to the main dust wiper/seal between shock housing and piston.
 - if the distance between the o-ring and the main dust wiper/seal is 10mm, the air pressure is matching to your weight
 - if the distance between the o-ring and the main dust wiper/seal is less than 10mm, the air pressure of the air chamber is too high and should be carefully reduced by using the bleed knob of the shock pump until the distance is 10mm.
 - if the distance between the main dust wiper/seal is bigger than 10mm, the air pressure of the air chamber is too low and should be increased by using the shock pump until the distance is 10mm.

SET-UP OF REBOUND NUDE 2 SHOCK

“Rebound” describes the speed the shock comes back to its original length after absorbing an obstacle.

By using the rebound adjuster knob (S4) you can adjust the rebound step by step.

Please refer to the following instruction:

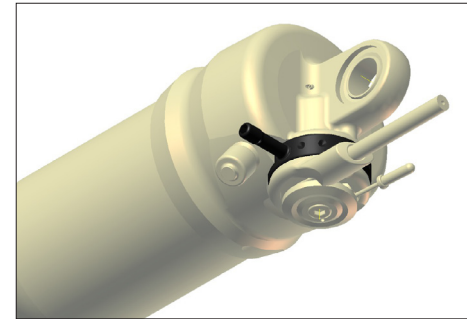

Ride your bike off a pavement (remain in the saddle) and check how many times it bounces.

- If it bounces 1-2 times, the set up is good.
- If it bounces more than 3 times the rebound is too fast. Turn the knob 1-2 “clicks” clockwise
- If it does not bounce the rebound is too slow. Turn the knob 1-2 “clicks” counter clockwise.

In case you want even more detailed figures of air pressure or tuning hints, you can download a program under www.scott-sports.com in the support area of the website

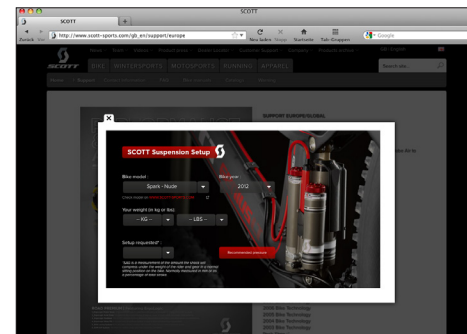

IMPORTANT:

Note that you have to mount the Scott Nude 2 Shock always as shown underneath.
Mounting the rear shock in a different position can cause severe damages to the frame, the linkage levers and the rear shock.
Same for the DT M210 and X-Fusion E1 shock on some of the Spark models.

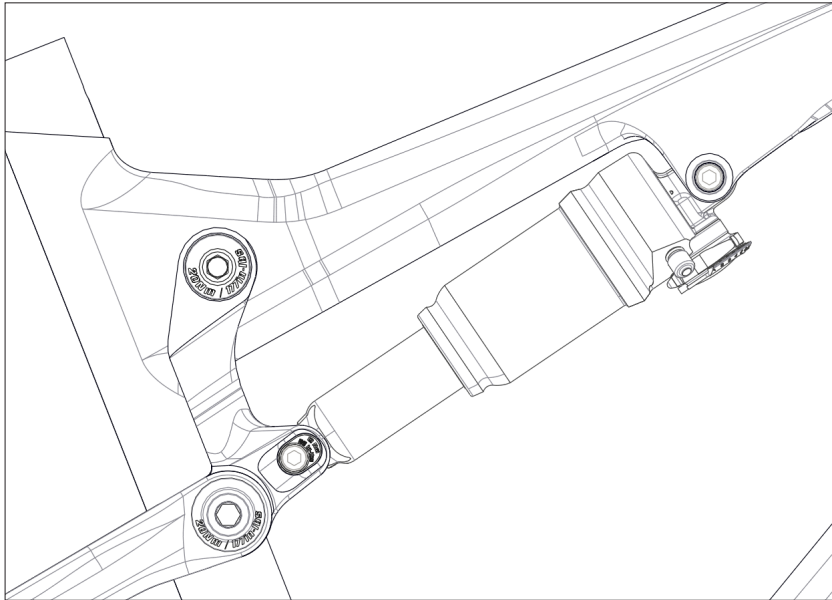

IMPORTANT:

After a dismantlement of the rear shock, both fixing bolts should be tightened with a tightening torque of 5Nm/44in-lbs.
If this is not done correctly the rear shock can be damaged.

SET-UP OF OTHER SHOCK MODELS

Scott strongly recommends using only the Scott Nude 2 (DT M210/X-Fusion E1 Shock with the Spark bike, as we designed both parts for a perfect matching combination with a linear suspension rate.

Also on those shock models the SAG should be 10mm.

For all basic steps on inflating the shock and adjusting the rebound please refer to the description of the Nude 2 TC set-up.

OTHER SHOCK MODELS ON SPARK

If you want to use a different rear shock model than the one originally on the bike, please make sure that the shock will not in any position hit the frame and cause a damage to the frame.

Please follow the instruction below:

Please make sure that the rear shock or its accessory parts do not touch the frame when mounting or suspending.

For doing so release the air/remove the coil, install the shock and compress the shock completely.

If the shock touches the frame while doing so, do not use this shock in order to avoid damage to frame, swingarm or shock.

HEADSET OPTIONS

Spark features different versions of headset systems.

1. A tapered headset and fork steerer system to match with semi-integrated headsets of the "50-61"mm range with ID of Headtube of 44.0mm on top and 54.9mm on the lower end.

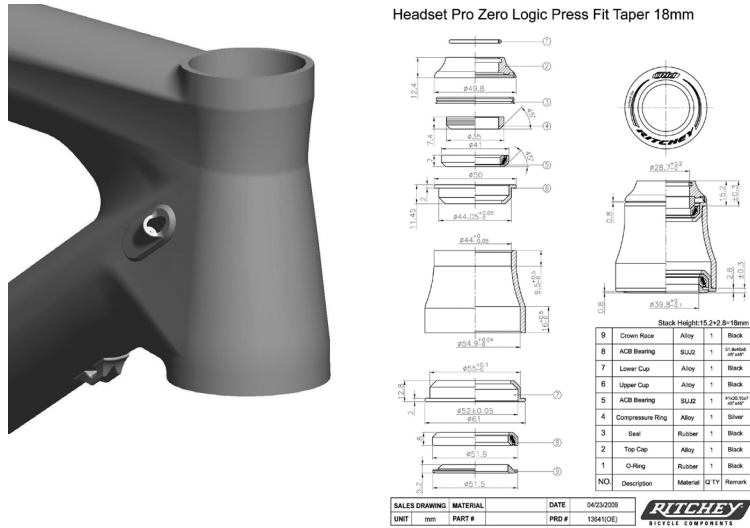

Ritchey WCS Carbon Zero Tapered	PF 50-61mm	18mm UD	PRD 13636
Ritchey PRO Tapered	PF 50-61mm	12.9mm	PRD 13640

It is also possible to use forks with a standard 1 1/8" steerer tube when using a reducer headset such as e.g.

Ritchey WCS Carbon Zero Tapered	PF 50-61mm	18mm UD for 1 1/8" fork	
---------------------------------	------------	-------------------------	--

2. A straight 1 1/8" headset and fork steerer system to match with semi-integrated headsets with an ID on the headtube of 44.0mm on top and lower end
This is a standard part in the market and should be available from several parts manufacturers.

BOTTOM BRACKET (BB) ON SPARK

All carbon front frames of Spark have a BB shell for BB92PF standard.

This matches to several bearing and crankset models of Shimano, SRAM, FSA and others.

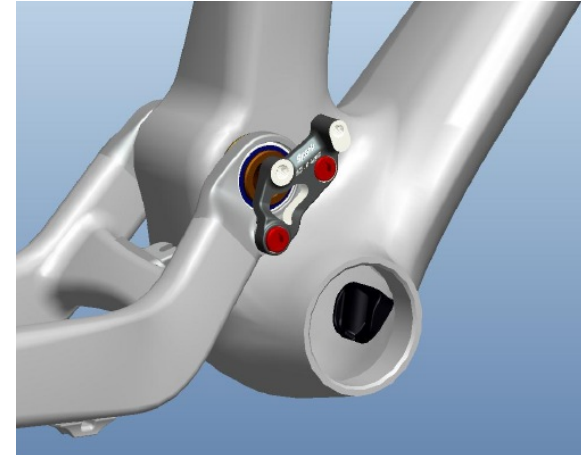

All alloy front frames of Spark have a BB shell for 73mm BSA standard.

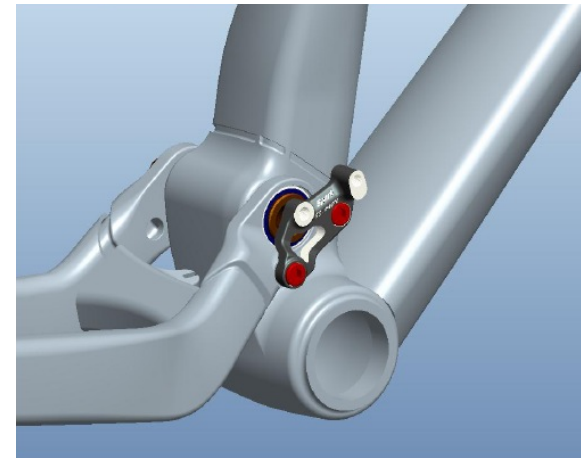

ADJUSTABLE BB HEIGHT

On Spark bikes equipped with the Nude 2 TC shock you can adjust the BB height above ground in 2 positions by flipping a geometry chip located on the linkage bar shock mount.

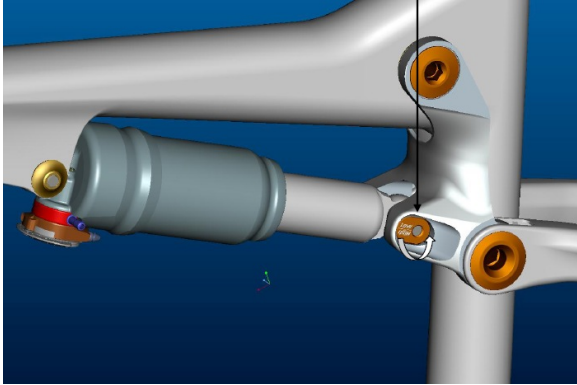

1. low BB for lower center of gravity over ground
2. high BB for bigger clearance between pedals/crankset and obstacles on the ground

IMPORTANT:

It is not possible to use this geometry chip with other shock models than the Nude 2. The shock might collide with parts of the frame or linkage bar. Models originally equipped with another shock than the Nude 2 TC will have a chip with a centered shock bolt hole.

FRONT DERAILLEUR (FD) MOUNTING DETAILS

On all Spark frames you will find a Shimano E-type front derailleur but fixed directly on the swingarm without the plate that is fixed normally between the bottom bracket bearing cup and the bottom bracket housing of the front triangle or a SRAM Direct Mount Type S3 FD.

Please note that you always need to use the adapter plate attached to the bike or frame set between chainstay and front derailleur.

This adapter can be ordered at the Scott distribution with parts number:

223304 FD-Mount Plate Set Spark 2012

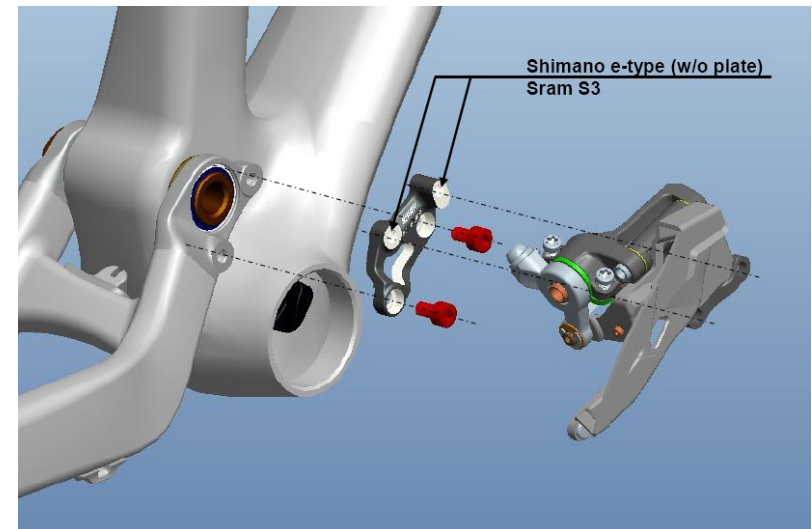

SPARK CABLE ROUTING

The direct and straight cable system on all our full suspension models offers perfect shifting performance combined with lightweight and high resistance against water and dirt.

CARBON FRONT FRAMES:

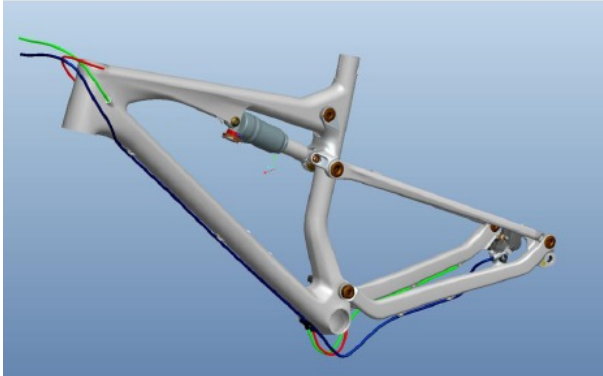

The carbon frames of Spark have an internal shifting cable routing with cable stops on the front end of the downtube as shown in the drawing below.

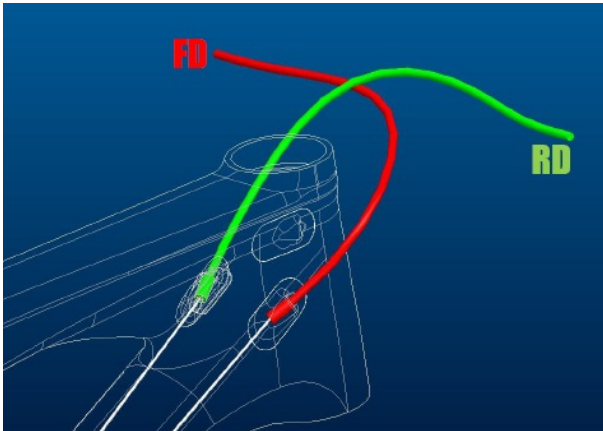

Please note that the inner cables need to cross each other 1 time on the inside of the downtube before you pull them out through the cable slot on the lower downside of the downtube.

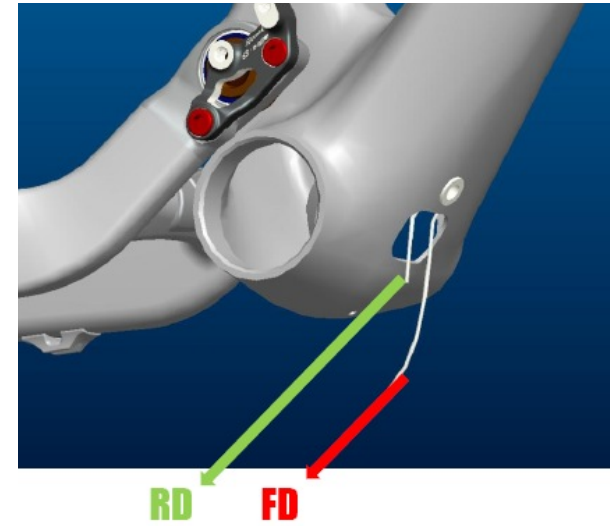

Push the cables through the cable guide as shown below and fix the cable guide on the downtube with a 3mm allen key and a tightening torque of 4Nm/35in/lbs

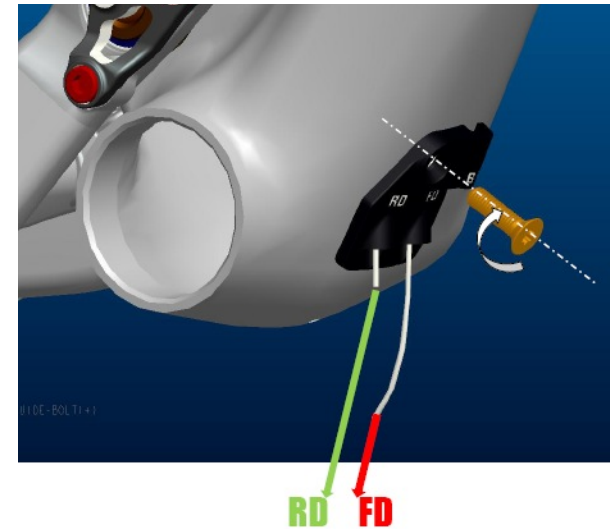

Push the outer cable housings on the cables into the cable guide but make sure to respect the needed length as shown in the next drawing!

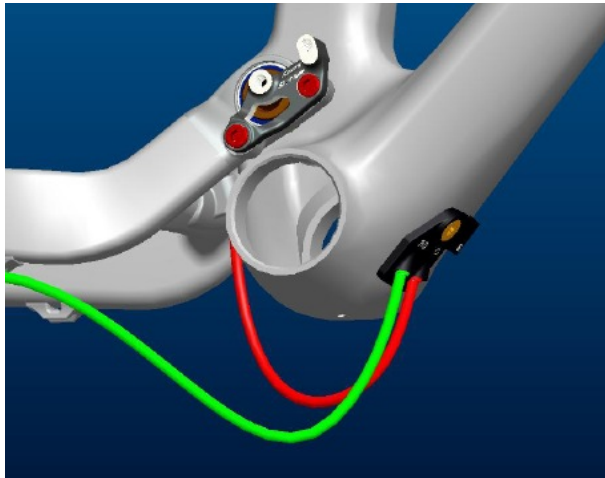

Please make sure to respect the 40mm distance between the cables and the BB (bottom bracket) housing to avoid “ghost-shifting” and/or damages on the shift cables and brake hoses.

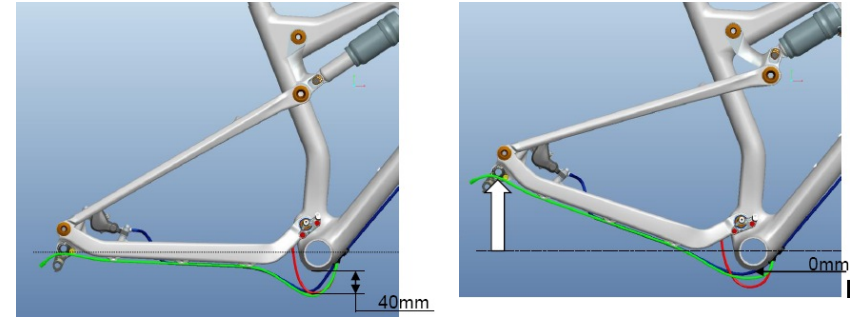
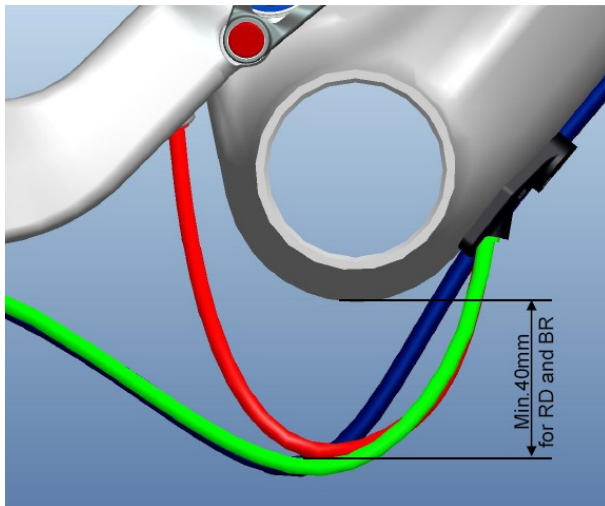

For the rear brake please assemble the cable as shown in the following drawings:

Please keep in mind to have a minimum distance of 40mm between the brake hoses and the BB housing as abovementioned!

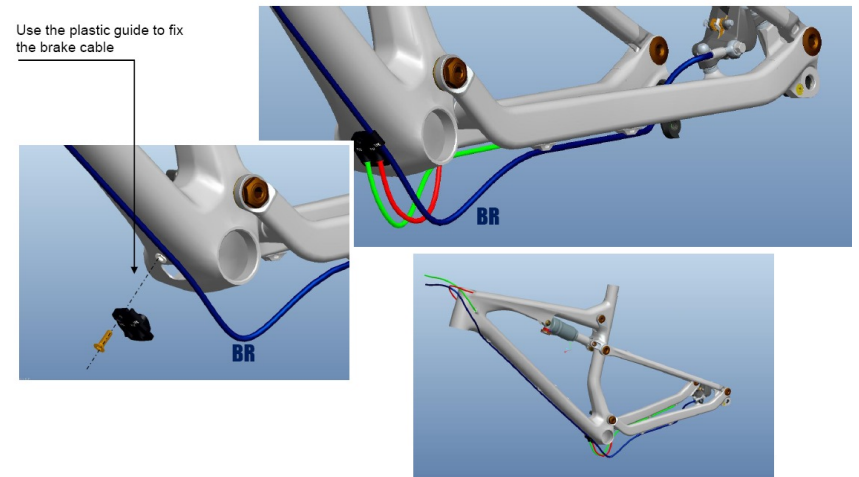

The cable guide can be ordered via the Scott distribution with parts number:

223305 BB Cableguide Spark 2012 carbon

ALLOY FRONT FRAMES:

Please fix the cable housings and the brake hose on the frame on the cable mounts with cable zippers.

Please make sure to respect the 40mm distance between the cables and the BB (bottom bracket) housing to avoid "ghost-shifting" and/or damages on the shift cables and brake hoses.

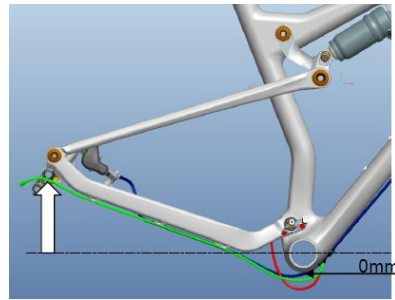
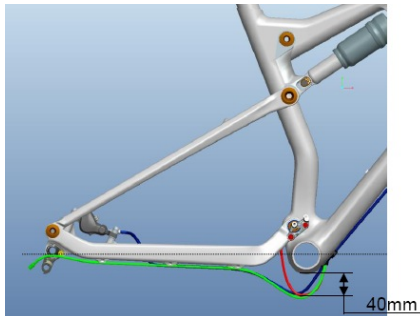
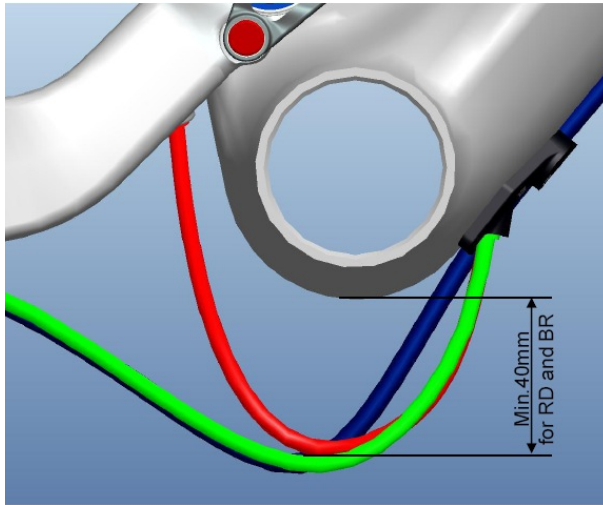

For the rear brake please assemble the cable as shown in the following drawings:

Please keep in mind to have a minimum distance of 40mm between the brake hoses and the BB housing as abovementioned!

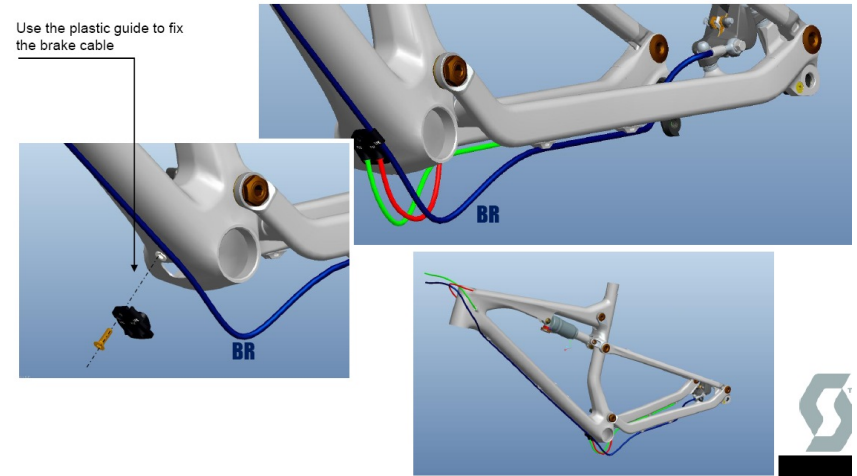

The cable guide can be ordered via the Scott distribution with parts number:

223305 BB Cableguide Spark 2012

ADJUSTMENT OF SEATPOST-HEIGHT

IMPORTANT:

The seatpost has to be inserted into the seat tube at a minimum of 100mm.

Never use another seatpost diameter than 31.6mm or try to use a shim/reducer between seatpost and frame.

REPLACEABLE DROPOUT

On Spark bikes of model year 2012 you can replace the rear derailleur hanger.

Depending on the different models you'll find following options:

1. 142mm axle with RWS 142/12

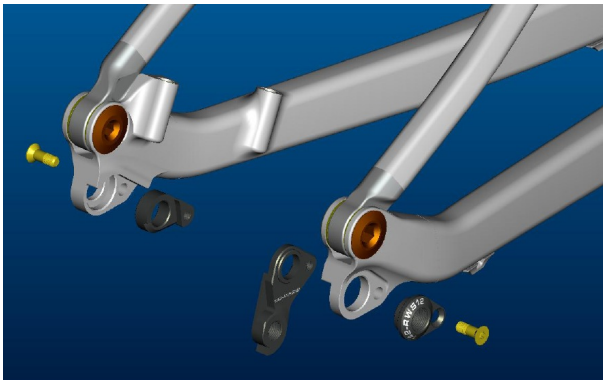

The complete set is available via the Scott distribution with parts number 219574, the right side replaceable RD hanger with 219577.

2. Regular 135 mm rear axle with standard QR

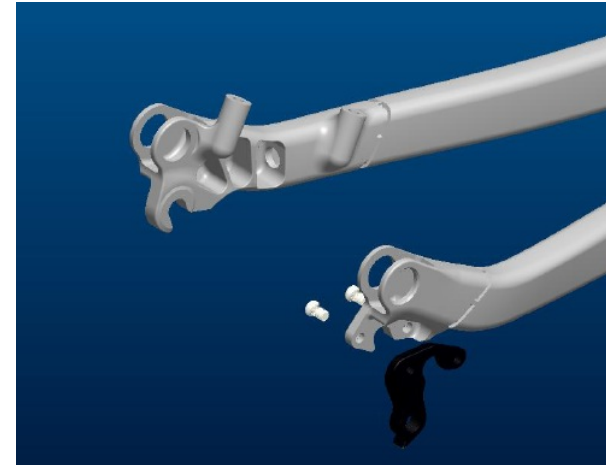

The replaceable hanger is available via the Scott distribution with parts number 206473.

In case you want to use other RWS standards we can offer as after-market parts for specific wheelsets following parts via the Scott distribution:

.....
RWS 135/12 parts set: 219574, right side replaceable RD hanger available with 219576

.....
RWS 135/5 parts set: 219572, right side replaceable RD hanger available with 219575
.....

REAR DISC BRAKE MOUNT

Spark can be used with 3 different disc rotor sizes on the rear brake.

The rear disc brake on Spark is Postmount (PM) Standard on the left seatstay and it is possible to use disc rotors with 160, 180 and 185mm diameter.

Please note that for the assembly of 180 and 185mm rotors you might need adapters/washers between the PM port on the frame and the brake calliper.

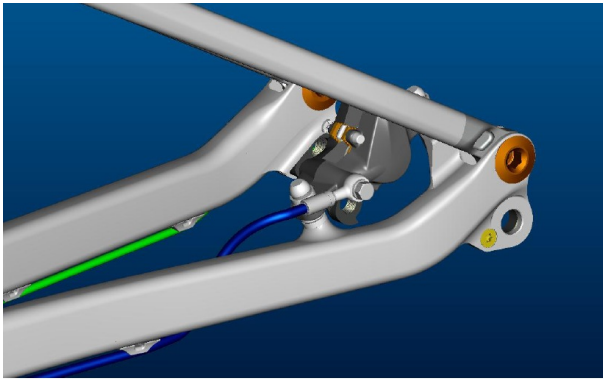

FRONT FORK SET-UP/ CHANGE OF FRONT FORK:

For the set up of the front fork please use the fork specific manual attached to the bike.

We recommend using front forks with a travel of 120mm (26") and 100mm (29"), as this will not influence the geometry and alter handling of the bike.

For details on the technical length of the recommended forks please refer to the Tech Info Chart beforementioned.

PIVOT MAINTENANCE

The pivot and bearings on SCOTT Genius are extremely easy to maintain.

An external treatment with a grease spray after every bike wash is all you have to do. We do not recommend heavy grease sprays since these will leave a film on the parts which is difficult to remove. We recommend the same for the chain also.

If you have to change the bearings you can order them included in a service kit at your local SCOTT dealer or buy them with international parts number as shown above in the specs list in a hardware store.

In case of a change of the bearings or of the rear swingarm you should contact your local SCOTT dealer as you need special tools for disassembly and assembly.

WARRANTY

Model

Year

Size

Frame Nr.

Shock Nr.

Date of purchase

WARRANTY

SCOTT bikes are made using the most innovative production and quality methods. They are equipped with best components of well known parts suppliers.

Doing so SCOTT warrants its frames and swingarms for five years (subject to compliance with maintenance ranges, see below) and SCOTT forks (provided it is a fork of SCOTT) for two years for defects in material and/or workmanship in case of purchase of completely assembled bikes.

This warranty of 5 years for the frames shall only be granted in case once a year a maintenance service has been effected according to maintenance requirements as set forth in this manual by an authorised SCOTT dealer.

The authorised SCOTT dealer shall confirm the effected annual maintenance service by stamp and signature.

In case such an annual maintenance service has not been effected the warranty of 5 years for the frame shall be reduced to 3 years.

Costs for maintenance and service have to be born by the owner of the SCOTT bike.

On Gambler, Voltage FR and Volt-X the warranty period is limited to 2 years.

The warranty period starts at the day of purchase. This warranty is limited to the first buyer, what means the first person who uses the bike and only with the use it was made for. Furthermore, this warranty is limited to purchases via authorized SCOTT-dealers

The warranty is solely granted in case of purchase of a completely assembled bike to the explicit exclusion of purchases of not completely assembled bikes.

In case of a warranty claim the decision to repair or to replace the defective part is up to SCOTT. Non defective parts will only be replaced at the guarantee's own expense.

Fair wear and tear is not covered by the warranty.

A complete list of all parts of wear and tear can be found in the next chapter of this manual.

In addition, you will find at the end of this manual a protocol for the handing over of the bike which will remain in copy at the SCOTT dealer after acceptance and signature of the consumer.

It is obligatory to show this protocol of handing over together with the defective part in case of a warranty claim given that it provides evidence of purchase. Otherwise no warranty is granted.

In principle, this warranty is granted worldwide. Claims must be made through an authorized dealer, for information regarding the nearest dealer, write or call this company or the national SCOTT distributor.

Normal wear, accident, neglect, abuse, improper assembly, improper maintenance by other than an authorized dealer or use of parts or devices not consistent with the use originally intended for the bicycle as sold are not covered by this warranty.

Hereby SCOTT grants a voluntarily manufacturer's warranty. Additional entitlements according to national warrant of merchantability are reserved.

For warranty info on the Nude 2 shock please refer to the attached manual of DT Swiss.