



GAMBLER

SCOTT 2014 BIKE OWNER'S MANUAL

SCOTT SPORTS SA | 17 RTE DU CROCHET | 1762 GIVISIEZ | SWITZERLAND
© 2013 SCOTT SPORTS SA, ALL RIGHTS RESERVED | SCOTT-SPORTS.COM
DISTRIBUTION: SSG (EUROPE) DISTRIBUTION CENTER SA
P.E.D ZONE C1, RUE DU KIELL 60 | 6790 AUBANGE | BELGIUM | v3.2/20130710





The Gambler should be adjusted exactly to the current rider for reaching maximum safety and fun while riding.

All adjustments should be done at the local SCOTT dealer or following to this manual.

In order to avoid technical problems or any harm please contact in case of doubts your authorized SCOTT dealer.

CONTENT

Gambler Concept	P. 004
Geometry/Technical Data Gambler	P. 005
Headset	P. 007
Adjustable BB Height	P. 008
BB Standards.....	P. 009
Chainguide Standards	P. 010
Recommended Tools for the Shock Set-Up	P. 010
Basic Set-Up of Gambler Rear Suspension	P. 011
Adjustment of Seatpost Height	P. 013
Adjustable Drop Out System.....	P. 014
Cable Routing	P. 015
Front Fork Set-Up/Change of Front Fork	P. 016
Pivot Maintenance	P. 016
Front Fork Bumpers	P. 017
Warranty	P. 018

GAMBLER CONCEPT

Gambler is the result of several years of research and development, also in close cooperation with the riders of SCOTT 11 DH Team, searching for one of the most versatile and durable DH bikes available on the market, but still easy in set-up and maintenance.

SCOTT's focus was not only on lightweight but also on a durable frame with an optimized kinematics of the rear swingarm.

Gambler was designed for riders looking for a race oriented DH bike offering rear wheel travel of 210mm.

SCOTT does not see frame, rear shock and kinematics as single components which are assembled together on a bike, but as a concept with all these components working together and offering an outrageous function by matching perfectly.

The Gambler Concept is based on a new designed multi-pivot technology.

In combination with the linear coil-over shock characteristics the kinematics guarantees a progressive suspension, adapted to smooth riding (beginning of travel) as well as extreme jumps (end of travel).

GEOMETRY/ TECHNICAL DATA GAMBLER

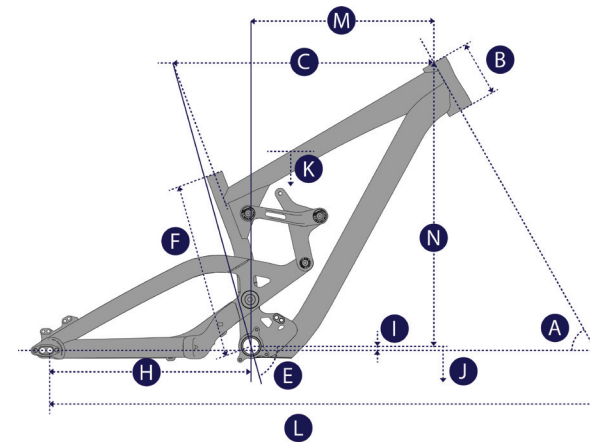

		Position LOW											
		A	B	C	E	F	H	I	J	K	L	M	N
Size	Head Angle	Head Tube	Top Tube horizontal	Seat Angle	BB Center to top of Seat Tube	Chainstay +15mm	BB Offset	BB Height	Stand-over Height	Wheel-base +15mm	Reach	Stack	
	°	mm inches	mm inches	°	mm inches	mm inches	mm inches	mm inches	mm inches	mm inches	mm inches	mm inches	mm inches
S	62.0°	115 4.53	525.0 20.67	75.6°	370.0 14.57	425 16.73	0 0	345 13.58	762.2 30.01	1160 45.67	374.0 14.72	589.0 23.19	
M	62.0°	115 4.53	550.0 21.65	75.6°	370.0 14.57	425 16.73	0 0	345 13.58	758.0 29.84	1185 46.65	399.0 15.71	589.0 23.19	
L	62.0°	115 4.53	574.5 22.62	75.6°	370.0 14.57	425 16.73	0 0	345 13.58	754.0 29.69	1210 47.64	424.0 16.69	589.0 23.19	

		Position HIGH											
		A	B	C	E	F	H	I	J	K	L	M	N
Size	Head Angle	Head Tube	Top Tube horizontal	Seat Angle	BB Center to top of Seat Tube	Chainstay +15mm	BB Offset	BB Height	Stand-over Height	Wheel-base +15mm	Reach	Stack	
	°	mm inches	mm inches	°	mm inches	mm inches	mm inches	mm inches	mm inches	mm inches	mm inches	mm inches	mm inches
S	62.7°	115 4.53	522.0 20.55	76.5°	370.0 14.57	421.5 16.59	+9.5 +0.37	354.5 13.96	767.6 30.22	1156 45.51	381.5 15.02	593.0 23.35	
M	62.7°	115 4.53	547.0 21.54	76.5°	370.0 14.57	421.5 16.59	+9.5 +0.37	354.5 13.96	763.5 30.06	1181 46.50	406.0 15.98	593.0 23.35	
L	62.7°	115 4.53	572.0 22.52	76.5°	370.0 14.57	421.5 16.59	+9.5 +0.37	354.5 13.96	760.0 29.92	1206 47.48	431.0 16.97	593.0 23.35	

TECHNICAL DATA GAMBLER

Travel	210mm/8.2"
Suspension Ratio	2.36
Piston stroke	89mm/3.5"
Shock length (Eye-Eye)	267mm/10.5"
Hardware Mainframe	22.2mm x 8mm
Hardware Linkage	60mm x 8mm
Seatpost diameter	31.6mm
Headset	1.5" straight, semi-integrated, OD 55mm
Fork travel	200mm
Fork length	571mm
BB housing	83mm/BB PF 104 (depending on model)
Chainguide system	ISCG05
Chainring	Maximum 38T
Rear hub width	150mm
Dropout options	+0mm/+15mm, SCOTT specific rear axle
Max. tire width	64mm/2.50"
Bearings	2 x 61805 (25 x 37 x 7) 6 x 6902 (15 x 28 x 7)

HEADSET

All Gambler models are designed for a semi-integrated headset for 1.5" headtubes with an outer diameter of the headtube of 55mm.

For details pls refer to the following drawing which is just used for reference. There are several parts manufacturers offering headsets for this dimension of the headtube.

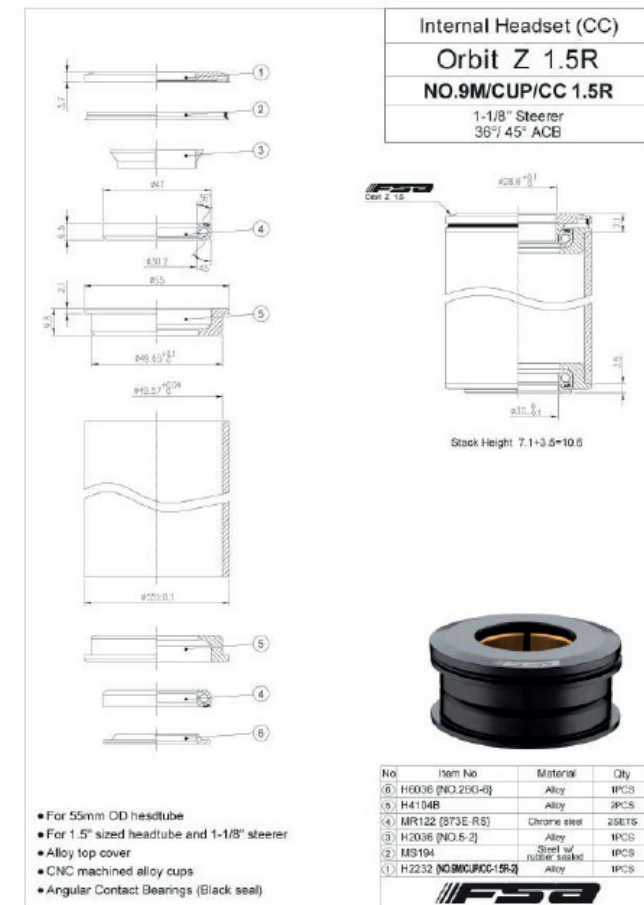

ADJUSTABLE BB HEIGHT

On the Gambler you can adjust the BB height above ground for 10mm between its 2 positions by a geo-chip.

Low position is at a BB offset of +0mm, high position is at +10mm offset.

In order to change the set-up please un-tighten the shockmount bolt with a 6mm allen key.

“Flip-flop” the “geo-chip” on both sides as shown in the drawing below and tighten the shock mount bolt again with a maximum tightening torque of 35Nm/ 308in/lbs.

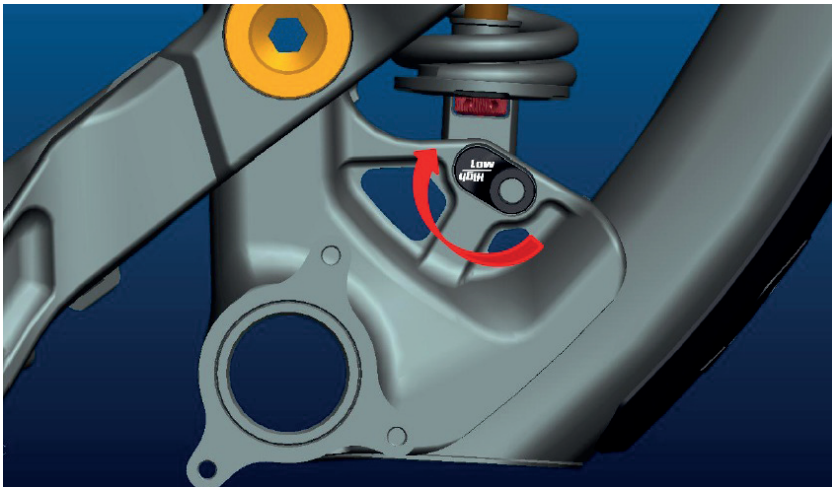

BB STANDARDS

On Gambler you will find 2 different BB options, depending on the model you bought:



1. BB PF 104 with a housing width of 104mm and an inner diameter of 41mm for PressFit bearings



2. Standard threaded BSA with 83mm housing width for threaded assembly bearing sets

CHAINGUARD STANDARDS

The Gambler is prepared on all models for an ISCG05 chainguard system.



RECOMMENDED TOOLS FOR THE SET-UP

Please read this manual and the manual of the rear shock manufacturer carefully before you start the set-up procedure.

In addition we strongly recommend using a tightening torque key with a 6mm allen key insert.

To simplify the check of the SAG (= negative travel) of the rear shock please use the "SAG-Boy" printed as a color-beam on the cover of this manual.

SET-UP GAMBLER

The Set-Up of the rear shock can be easily done within a few minutes.

Please take this time to avoid dangerous riding performance and to get the best out of your Gambler.

Please make sure that the coil spring on the shock matches to your riding weight (including your riding gear).

The basic set up of the shock spring is for size

S: 250 which corresponds to a rider weight of 50-60kgs

M: 300 which corresponds to a rider weight of 60-70kgs

L: 350 which corresponds to a rider weight of 70-80kgs

We recommend following coil springs:

50-60 kgs 250x3.50

60-70 kgs 300x3.50

70-80 kgs 350x3.50

80-90 kgs 400x3.50

For fine tuning the SAG and the corresponding eye-to-eye distance of the shock bolts you can tighten or release the pretension of the coil spring but please respect the maximum and minimum spring indications of the shock manufacturer.

The eye-to-eye distance between the shock bolts should be in basic set up 232mm (40% SAG/35mm SAG).

This length is also indicated on the cover of this manual by the colored beam of the SAG-Boy.

For further details on the shock set-up please follow the indications of the rear shock manufacturer attached to this bike.

BASIC SET-UP OF REBOUND

“Rebound” describes the speed the shock comes back to its original length after absorbing an obstacle.

By using the red rebound screw you can adjust the rebound step by step.

Please refer to the following instruction:

Ride your bike off a pavement (remain in the saddle) and check how many times it bounces.

1. If it bounces 1-2 times, the set up is good.
2. If it bounces more than 3 times the rebound is too fast. Turn the screw 1-2 “clicks” clockwise
3. If it does not bounce the rebound is too slow. Turn the screw 1-2 “clicks” counter clockwise.

Important:

Note that you have to mount the rear shock always as shown underneath.

Mounting the rear shock in a different position can cause severe damages to the frame, the linkage levers and the rear shock.

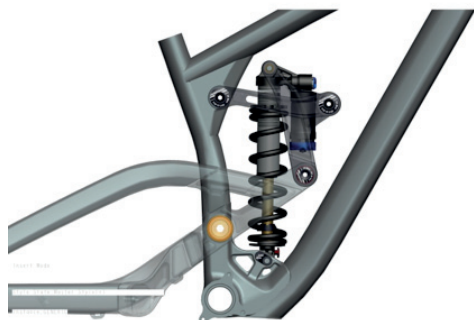

Important:

After a dismantlement of the rear shock, both fixing bolts should be tightened with a tightening torque of 35Nm/308in-lbs.

If this is not done correctly the rear shock can be damaged.

SET-UP OF OTHER SHOCK MODELS

SCOTT strongly recommends using only the originally specified shock with the Gambler bike, as we have chosen carefully both parts for a perfect matching combination.

If you want to use a different rear shock model than the one originally on the bike, please make sure that the shock will not in any position hit the frame and cause a damage to the frame.

Please follow the instruction below:

Please make sure that the rear shock or its accessory parts do not touch the frame when mounting or suspending.

For doing so release the air/remove the coil, install the shock and compress the shock completely.

If the shock touches the frame while doing so, do not use this shock in order to avoid damage to frame, swingarm or shock!

ADJUSTMENT OF SEATPOST-HEIGHT

Important:

The seatpost has to be inserted into the seattube at a minimum of 80mm.

Never use another seatpost diameter than 31.6mm or try to use a shim/reducer between seatpost and frame.

ADJUSTABLE DROP OUT SYSTEM

The Gambler offers the possibility to change the drop out hanger in case of damage, but you can also choose between 2 different rear-axle positions which result in 2 different wheelbases:



Important:

Please make sure to adjust the rear disc brake calliper position accordingly when changing the rear axle position!

CABLE ROUTING

The cable routing on Gambler is quite easy to do, please just use cable zippers on the cable parts on the tubes.

For the rear derailleur the housing is hidden inside the chainstay as shown in the drawing below.



FRONT FORK SET-UP/ CHANGE OF FRONT FORK

For the set up of the front fork please use the fork specific manual attached to the bike.

We recommend using front forks with a travel between 180 and 200 mm (568mm fork length), as this will not influence the geometry and alter handling of the bike.

PIVOT MAINTENANCE

The pivots and bearings on SCOTT Gambler are extremely easy to maintain. An external treatment with a grease spray after every bike wash is all you have to do. We do not recommend heavy grease sprays since these will leave a film on the parts which is difficult to remove. We recommend the same for the chain also.

If you have to change the bearings you can order them included in a service kit

229705

at your local SCOTT dealer or buy them with international parts number as shown above in the specs list in a hardware store.

FRONT FORK BUMPER

In order to avoid damages on the frame caused by the fork stanchions hitting the downtube in case of a crash the Gambler shows rivets on the front end of the downtube to assemble bumpers.

The bumpers can be replaced if needed. You can order them via the SCOTT distribution with article number:

229715 frame fork bumper Gambler

In order to replace them please use a 4mm allen key for the M5 bolt and please respect the maximum tightening torque of 5Nm/44in/lbs.

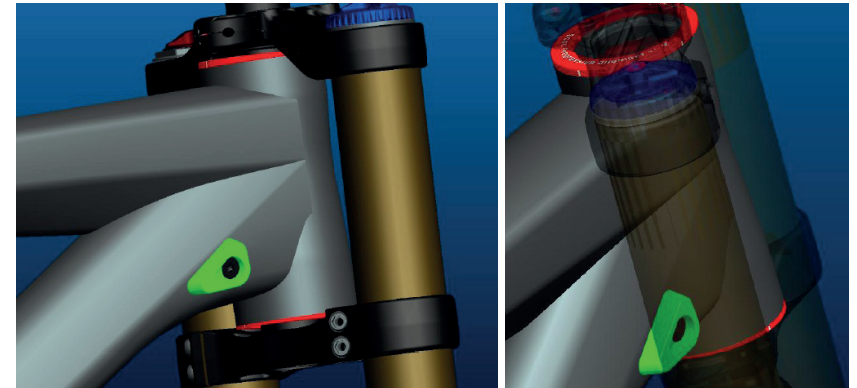

WARRANTY

Model

Year

Size

Frame

Date of purchase

WARRANTY

SCOTT bikes are made using the most innovative production and quality methods. They are equipped with best components of well known parts suppliers.

Doing so SCOTT warrants its frames and swingarms for five years (subject to compliance with maintenance ranges, see below) and SCOTT forks (provided it is a fork of SCOTT) for two years for defects in material and/or workmanship in case of purchase of completely assembled bikes.

This warranty of 5 years for the frames shall only be granted in case once a year a maintenance service has been effected according to maintenance requirements as set forth in this manual by an authorised SCOTT dealer.

The authorised SCOTT dealer shall confirm the effected annual maintenance service by stamp and signature.

In case such an annual maintenance service has not been effected the warranty of 5 years for the frame shall be reduced to 3 years.

Costs for maintenance and service have to be born by the owner of the SCOTT bike.

On Gambler, Voltage Fr and Volt-X the warranty period is limited to 2 years.

The warranty period starts at the day of purchase. This warranty is limited to the first buyer, what means the first person who uses the bike and only with the use it was made for. Furthermore, this warranty is limited to purchases via authorized SCOTT-dealers

The warranty is solely granted in case of purchase of a completely assembled bike to the explicit exclusion of purchases of not completely assembled bikes.

In case of a warranty claim the decision to repair or to replace the defective part is up to SCOTT. Non defective parts will only be replaced at the guarantee's own expense.

Fair wear and tear is not covered by the warranty.

A complete list of all parts of wear and tear can be found in the next chapter of this manual.

In addition, you will find at the end of this manual a protocol for the handing over of the bike which will remain in copy at the SCOTT dealer after acceptance and signature of the consumer.

It is obligatory to show this protocol of handing over together with the defective part in case of a warranty claim given that it provides evidence of purchase. Otherwise no warranty is granted.

In principle, this warranty is granted worldwide. Claims must be made through an authorized dealer, for information regarding the nearest dealer, write or call this company or the national SCOTT distributor.

Normal wear, accident, neglect, abuse, improper assembly, improper maintenance by other than an authorized dealer or use of parts or devices not consistent with the use originally intended for the bicycle as sold are not covered by this warranty.

Hereby SCOTT grants a voluntarily manufacturer's warranty. Additional entitlements according to national warrant of merchantability are reserved.