

CONTENT

| | |
|--|----------|
| > Traction Control-Functions | P. 02 |
| > Picture of the Genius Shock and Remote Control Lever | P. 03 |
| > Basic Set-Up of the Remote Control | P. 04 |
| > Recommended Tools for the Shock Set-Up | P. 05 |
| > Set-Up of Positive Air Chamber | P. 06/07 |
| > Set-Up of Negative Air Chamber | P. 06/07 |
| > Set-Up of Rebound | P. 08 |
| > More Details about Shock Set-Up | P. 08 |
| > Maintenance / Service Guide | P. 09 |
| > Important | P. 10/11 |
| > Warranty | P. 12/19 |

ENGLISH

DEUTSCH

FRANÇAIS

01

TRACTION CONTROL-FUNCTIONS

The heart of the TC-System is the newly developed and innovative Scott Genius Shock, offering three functions which make this system possible.

By using the remote lever you can choose between following functions:

1. ALL TRAVEL MODE: full travel of 125mm (Genius MC) resp. 90mm (Genius RC / Genius Contessa).

2. TRACTION MODE: by reducing the air volume inside the shock the travel of the shock will be reduced to around 60%, the characteristic of the air spring gets harder. This results in climbing without "bobbing" and offers still optimum traction of the rear wheel.

3. LOCK OUT MODE: the shock is locked, climbing on asphalt roads is now possible without any power loss. Simultaneously a blow-off-system prevents the shock being damaged in case the rider did not open the system while crossing obstacles.

You will find following positions on the remote lever:

[1]

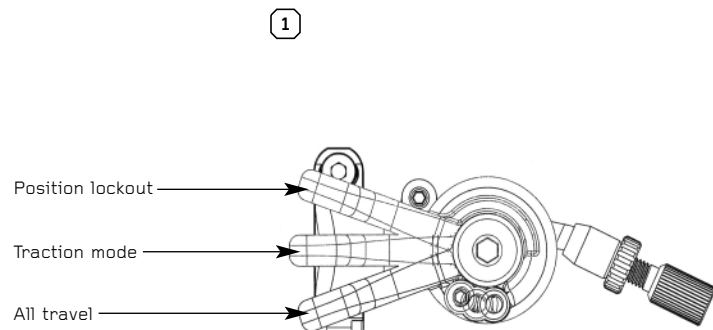

Traction Control-Functions

PICTURE OF THE GENIUS SHOCK AND REMOTE CONTROL LEVER

In the drawing of the shock and remote lever, shown below, you will see the parts indicated with numbers which will be used in the manual for the adjustment and set-up. [2] [3]

| | | | |
|----|------------------------|-----|----------------------|
| S1 | Upper Shock Bolt | S10 | Cable Clamping Screw |
| S2 | Lower Shock Bolt | S11 | Traction Mode Lever |
| S3 | Piggy-Back | S12 | Shock Piston |
| S4 | Shock Housing | L1 | Remote Lever |
| S5 | Rebound-Screw | L2 | Remote Control Cable |
| S6 | Positive Chamber Valve | L3 | Tension Screw |
| S7 | Negative Chamber Valve | L4 | Allen Screw |
| S8 | Cable Fixation Screw | | |
| S9 | Lock Out Lever | | |
| | | | |

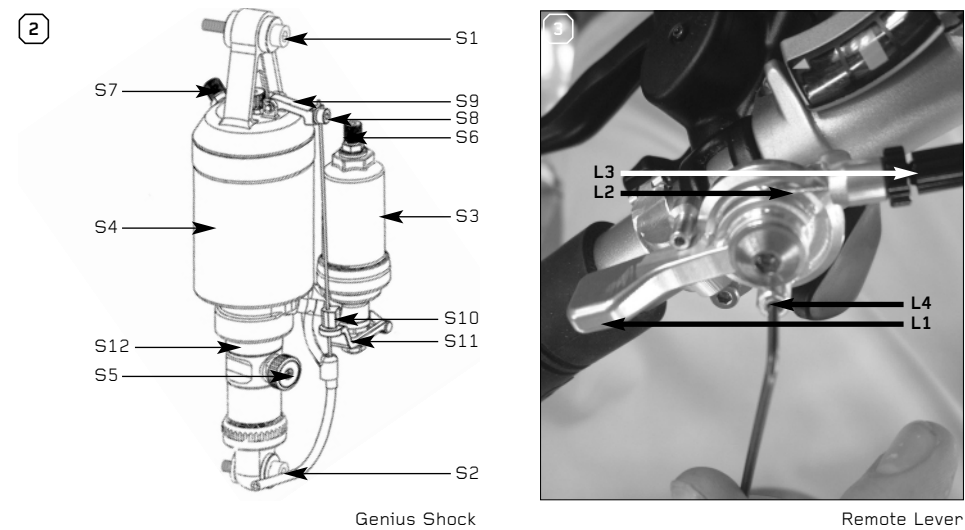

BASIC SET-UP OF THE REMOTE CONTROL

1. Put the remote lever (L1) to position "lock-out". **[1]**

2. Fix the remote control cable (L2) with the cable fixation screw (S8) using a 3mm allen key (tightening torque: 3 Nm) on the lock out lever (S9). **[3]**

3. Put the remote lever now to position "Traction Mode". **[1]**

4. Fix the cable clamping screw (S10) using a 3mm allen key (tightening torque 3Nm) on the traction mode lever (S11). **[4]**

5. When putting now the remote lever to position "All Travel" the cable will pull the traction mode lever downward and the shock will offer now the full travel. Check now the set-up for perfect function of remote lever and shock.

6. In case you want to fine-tune the brake-away power of the remote lever, you can do this by using a 2mm allen key and by turning the allen screw (L4). In case you want to readjust the tension of the remote control cable you can do this by using the tension screw (L3). **[5]**

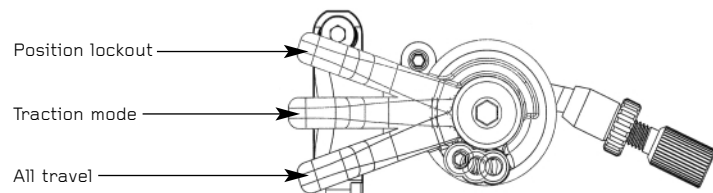

Traction Control-Functions

3



4



RECOMMENDED TOOLS FOR THE SHOCK SET-UP

PLEASE NOTE

Please clean regularly after riding off-road the shock piston (S12) and all other parts in motion of the shock with a soft and wet cloth to prevent from excessive wear and tear.

For the set-up of the shock we recommend to use the tools listed below:

- a shock pump with a scale up to 20 bars/300 psi with a special air valve connector preventing from air getting away while removing the pump from the shock valve and granting exact air pressure.

- Therefore we recommend the Scott Shock Pump which you can order at your local Scott-Dealer with parts number 15.1.834.208.0.000

- the SAG-Boy on the back of this manual



5



SET-UP OF POSITIVE AIR CHAMBER

IMPORTANT:

For all adjustments of the air spring the lockout lever has to be in position "all travel"

The positive air chamber contains the air-spring you "sit-on" while riding. **[7]**

To adjust the air pressure of the positive chamber of the Scott Genius Shock please refer to the following instruction:

1. Remove the valve cap of the black valve (S6) located on the Piggy-Back (S3).
2. Mount the shock pump with its adaptor on the valve.
3. Pump the recommended pressure into the Piggy-Back. On the housing of the Piggy-Back you will find a table showing in the black colored areas the recommended air pressure of the positive chamber according to the rider's weight.
4. When you reached the needed pressure remove the pump and put the valve cap on the valve.

| RIDER WEIGHT (KG) | AIR SETTING | AIR SETTING |
|-------------------|-------------|-------------|
| 60 | 6,9 | 3,1 |
| 65 | 7,4 | 3,4 |
| 68 | 8,0 | 3,9 |
| 68 | 8,6 | 4,3 |
| 70 | 9,1 | 4,7 |
| 75 | 9,7 | 5,1 |
| 80 | 10,2 | 5,5 |
| 85 | 10,8 | 6,0 |
| 90 | 11,4 | 6,4 |
| 95 | 11,9 | 6,8 |

| RIDER WEIGHT (KG) | AIR SETTING | AIR SETTING |
|-------------------|-------------|-------------|
| 50 | 5,2 | 2,1 |
| 55 | 5,6 | 2,4 |
| 60 | 6,0 | 2,7 |
| 65 | 6,5 | 3,1 |
| 70 | 6,9 | 3,4 |
| 75 | 7,3 | 3,7 |
| 80 | 7,7 | 4,0 |
| 85 | 8,2 | 4,4 |
| 90 | 8,6 | 4,7 |
| 95 | 9,0 | 5,0 |

7



Positive Air Chamber

SET-UP OF NEGATIVE AIR CHAMBER

The negative air chamber contains the air-spring influencing the brake-away and characteristic while absorbing shocks. A too high brake-away can cause a non-secure and uncomfortable ride. **[8]**

To adjust the air pressure of the negative chamber of the Scott Genius Shock please refer to the following instruction:

1. Remove the cap of the silver valve (S7) located on the shock housing (S4).
2. Mount the shock pump with its adaptor on the valve.
3. Pump the recommended pressure into the shock housing. On the housing of the piggy-back you will find a table showing in the silver colored areas the recommended air pressure of the negative chamber according to the rider's weight.
4. When you reached the needed pressure remove the pump and put the valve cap on the valve.

8



Negative Air Chamber

We recommend to make sure that the pressure balance between positive and negative chamber follows the recommendations shown on the piggy-back.

Not doing so may cause a loss in performance or comfort or may result in damage of the shock.

After adjusting positive and negative chamber according to the rider's weight you can double check by using the SAG-Boy, which is on the back of the manual, if the SAG (negative travel) is well adjusted.

The negative travel is important when crossing grooves or holes on the trail.

If the bike is well adjusted the rear wheel and the swingarm will roll through the groove without the mainframe moving.

The SAG should be 15-20% of the travel for race oriented riders and 20-25% of the travel for comfort oriented riders.

The SAG-Boy indicates the recommended eye-to-eye distance of the shock bolts of the different Genius models.

9



To check the adjustment, please follow as shown below:

1. Sit on the bike, put your feet on the pedal. **[9]**
2. Ask a second person, to put the color beam of the SAG-Boy, recommended for your bike model, aside the eye-to-eye distance of the shock bolts.
3. If the distance between the bolts is corresponding to the length of the color beam, the air pressure is matching to your weight
4. If the distance between the bolts is shorter than the length of the color beam, the air pressure of the positive chamber is too high and should be carefully reduced by using the bleed knob of the shock pump until the measures are corresponding. **[10]**
5. If the distance between the bolts is longer than the length of the color beam, the air pressure of the positive chamber is too low and should be increased by using the shock pump until the measures are corresponding.

10



SET-UP OF REBOUND

"Rebound" describes the speed the shock comes back to its original length after absorbing an obstacle.

By using the red rebound screw (S5) you can adjust the rebound step by step.

Please refer to the following instruction:

Ride your bike off a sidewalk (remain in the saddle) and check how many times it bounces.

1. If it bounces 1-2 times, the set up is good.
2. If it bounces more than 3 times the rebound is too fast. Turn the screw 1-2 "clicks" clockwise.
3. If it does not bounce the rebound is too slow. Turn the screw 1-2 "clicks" counter clockwise. **[11]**

11

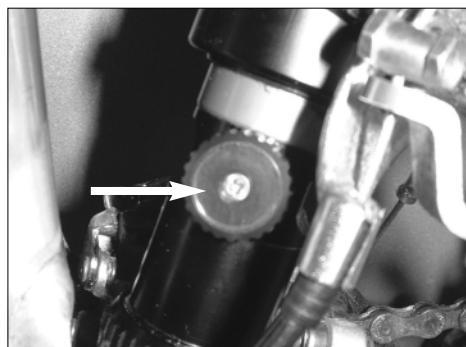

Rebound Knob

MORE DETAILS ABOUT SHOCK SET-UP

In case you want more exact numbers of the shock air pressure than shown on the decal on the piggy-back or you're looking for tuning hints including different shock characteristics of the Genius Shock, please have a look at

www.scottusa.com

In addition you can download this tuning program on your pc.

MAINTENANCE / SERVICE GUIDE

Please clean regularly after riding off-road the shock piston (S12) and all other parts in motion of the shock with a soft and wet cloth or if needed with mild soap to prevent from excessive wear and tear.

Please check that the valve caps are always fixed completely on the valves to avoid damages of the valves or inner parts of the shock caused by dust.

For maintenance and service please refer to the following table:

| Maintenance period | New | Every ride | Every 8 hours | Every 40 hours | Every 1000 hours / min. 1 x year |
|---|-----|------------|---------------|----------------|----------------------------------|
| Check of air pressure | × | | × | | |
| Check of rebound | × | | × | | |
| Clean shock bushings, check for tear and wear, grease | | | | × | |
| Change of oil/inspection at Scott Shock Service | | | | | × |
| Clean shock housing | | × | | | |
| Clean Lockout mechanism | | × | | | |

IMPORTANT

The Scott Genius Shock is pressurised. Never open, disassemble or rework the shock. Only a qualified and authorized Scott service staff/shock service center should do this.



To open a shock which is under pressure can be dangerous and may cause injuries!

The Scott Genius Shock always must be adjusted to the rider's weight to warrant perfect function.

Therefore check before every ride the shock for fitting air pressure.

Riding a defective or not properly working shock can result in the loss of control over the bike and may cause severe or dangerous injuries!

In case you want to disassemble the shock from the bike for service or other reasons please note the recommended tightening torque of **10Nm** for the shock bolts.

Scott recommends strongly the use of a torque key to prevent from damages on shock, shock bushings or frame.

In addition the shock bolts should be fixed with Loctite medium (blue) to prevent the bolts from getting unscrewed.

Damages caused by improper assembly or bad maintenance as mentioned above, are not covered by warranty.

Once the recommended check up is made by Scott or a shock service authorized by Scott, it is reported in the maintenance schedule at the end of the manual, which will then enable you to claim for warranty within the warranty period.

The owner of the shock is responsible for the costs of the service.

To ship the shock to Scott or the shock service authorized by Scott please contact your local Scott dealer.

WARRANTY

Model _____

Year _____

Size _____

Frame _____

Scott warrants its Genius Shock for two years for defects in material and/or workmanship.

The warranty period starts with the day of purchase.

It is obligatory to give a copy of the bill of purchase together with the shock to Scott.

In case the bill can not be shown Scott is free to reject the warranty claim.

Following damages are not covered by warranty:

- improper use
- damages on the piston seals caused by high pressure washers
- damages in the surface of the shock or piston caused by cable housings, stones or crashes
- any attempts to disassemble the rear shock
- changes in technical specifications
- oil changes not made at Scott or Shock Service Centers authorized by Scott
- neglecting the service and maintenance periods mentioned in the maintenance schedule (please refer to the maintenance schedule listed above in this manual)

In addition following parts are not covered by warranty:

- all seals and mud scrapers
- all piston bushings and sliders
- the surface of the piston
- the fixation bushings
- the shock bolts

Claims must be made through an authorized Scott dealer. For information regarding the nearest dealer, write or call this company or the national Scott Distributor.

SCOTT SERVICE PLAN

| | | | |
|--------------|-------|--------------------------|-------|
| Model | _____ | Service comment : | _____ |
| Year | _____ | | _____ |
| Size | _____ | | _____ |
| Frame | _____ | | _____ |
| | | | _____ |
| | | | _____ |
| | | | _____ |
| | | | _____ |
| | | | _____ |
| | | | _____ |

Date of Service:

Dealers Signature:

SCOTT SERVICE PLAN

| | | | |
|--------------|-------|--------------------------|-------|
| Model | _____ | Service comment : | _____ |
| Year | _____ | | _____ |
| Size | _____ | | _____ |
| Frame | _____ | | _____ |
| | | | _____ |
| | | | _____ |
| | | | _____ |
| | | | _____ |
| | | | _____ |
| | | | _____ |

Date of Service:

Dealers Signature:

SCOTT SERVICE PLAN

| | | | |
|--------------|-------|--------------------------|-------|
| Model | _____ | Service comment : | |
| Year | _____ | | _____ |
| Size | _____ | | _____ |
| Frame | _____ | | _____ |
| | | | _____ |
| | | | _____ |
| | | | _____ |
| | | | _____ |
| | | | _____ |
| | | | _____ |

Date of Service:

Dealers Signature:

SCOTT SERVICE PLAN

| | | | |
|--------------|-------|--------------------------|-------|
| Model | _____ | Service comment : | |
| Year | _____ | | _____ |
| Size | _____ | | _____ |
| Frame | _____ | | _____ |
| | | | _____ |
| | | | _____ |
| | | | _____ |
| | | | _____ |
| | | | _____ |
| | | | _____ |

Date of Service:

Dealers Signature:

SCOTT SERVICE PLAN

| | | | |
|--------------|-------|--------------------------|-------|
| Model | _____ | Service comment : | |
| Year | _____ | | _____ |
| Size | _____ | | _____ |
| Frame | _____ | | _____ |
| | | | _____ |
| | | | _____ |
| | | | _____ |
| | | | _____ |
| | | | _____ |
| | | | _____ |

Date of Service:

Dealers Signature:

SCOTT SERVICE PLAN

| | | | |
|--------------|-------|--------------------------|-------|
| Model | _____ | Service comment : | |
| Year | _____ | | _____ |
| Size | _____ | | _____ |
| Frame | _____ | | _____ |
| | | | _____ |
| | | | _____ |
| | | | _____ |
| | | | _____ |
| | | | _____ |
| | | | _____ |

Date of Service:

Dealers Signature: